

FK DN 40÷300

BUTTERFLY VALVE



FK DN 40÷300

The FK is a butterfly valve for shutting off or regulating flow, with structural characteristics that make it ideal for industrial applications requiring high performance and longterm reliability. This valve is also equipped with the customisable Labelling System.

BUTTERFLY VALVE

- Interchangeable Disk in PVC-C with through shaft, available in different thermo-plastic materials: PVC-U, PP-H, ABS, PVDF
- Overall dimensions of the valve in accordance with standard ISO 5752 and EN 558 (DN 40÷65 and DN 250÷350 Long Series 16, DN 80÷200 Medium Series 25, DN 400 according to internal specifications)
- Can also be installed as an end line valve, bottom discharge valve or tank dump valve
- **Special Lug version** PN 10 fully drilled to EN 1092-1 or ANSI B16.5 cl.150 with **molded-in AISI 316 stainless steel threaded inserts**
- Possibility of installing a manual reducer or pneumatic and/or electric actuators by applying ISO standard drilling pattern PP-GR flanges. DN 40 ÷ 200 valve fitted with plate with rack in PP-GR. For actuated versions with flange drilled according to ISO 5211 F05, F07, F10
- DN 250÷300 valve, fitted with one-piece top flange in high mechanical strength PP-GR with mounting flange for internal components with drilling according to standard ISO 5211 F10, F12, F14
- Possibility to have handle with integrated LSQT limit micro switch, even as a retrofit in existing installations

Technical specifications	
Construction	Bi-directional centric butterfly valve
Size range	DN 40 ÷ 300
Nominal pressure	Wafer version DN 40 ÷ 50: PN 16 with water at 20° C DN 65÷250: PN 10 with water at 20° C DN 300: PN 8 with water at 20° C Lug version DN 65÷200: PN 10 with water at 20° C DN 250÷300: PN 6 with water at 20° C
Temperature range	0 °C ÷ 100 °C
Coupling standards	Flanging system: EN ISO 15493, ISO 7005-1, EN 1092-1, ANSI B16.5 Cl.150, JIS B2220
Reference standards	Construction criteria: EN ISO 16136, EN ISO 15493 Test methods and requirements: ISO 9393 Actuator couplings: ISO 5211
Valve material	Body: PP-GR Disk: PVC-C Stem: STAINLESS steel AISI 316
Seal material	Liner: EPDM, FKM
Control options	Hand lever operated (DN 40÷200), Gear Box, pneumatic actuator, electric actuator

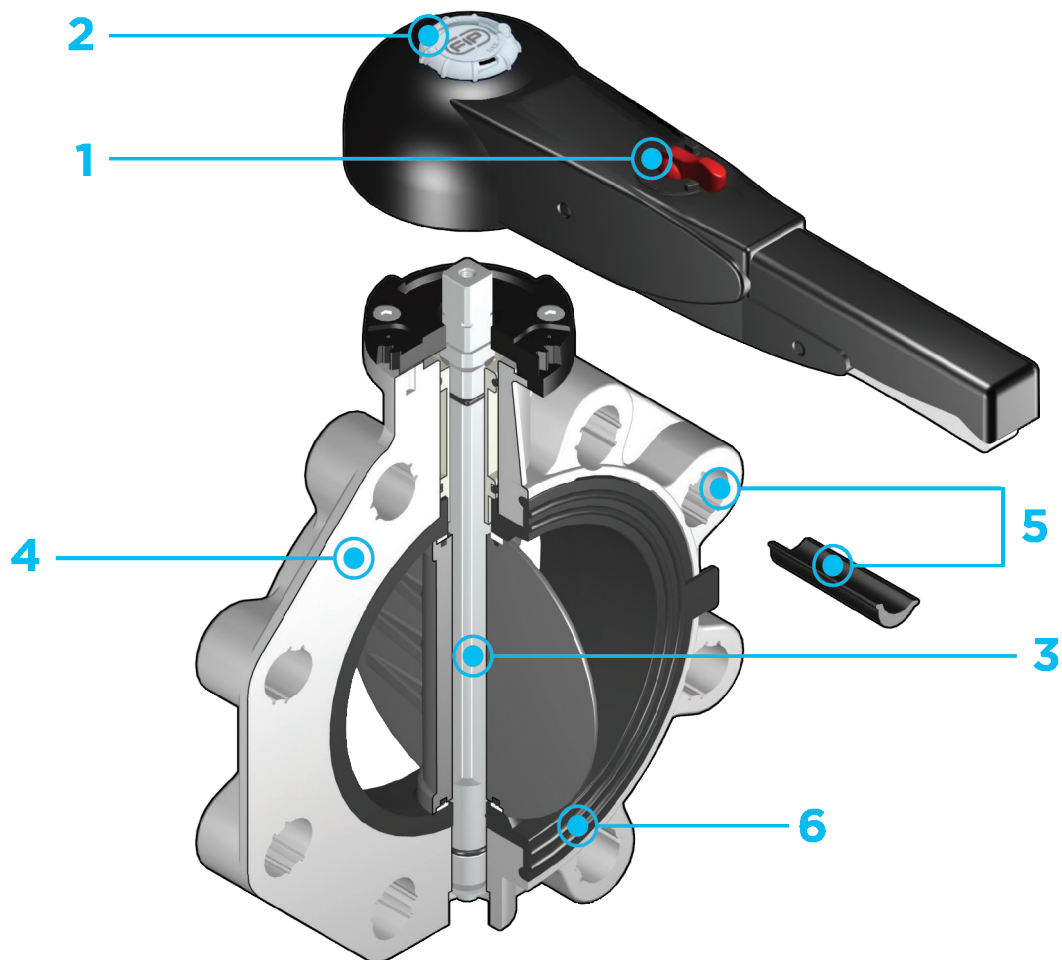

1 Ergonomic handle in **HIPVC** equipped with **locking and unlocking device, release, quick operation and graduated adjustment** in 10 intermediate positions (DN 40÷200). The operating range, starting from the first few degrees of valve opening, also guarantees extremely low pressure drops.

2 **Customisable Labelling System:** integrated module in the handle, made of a transparent protection plug and a customisable tag holder using the LSE set (available as an accessory). The **customisation** lets you **identify the**

valve on the system according to specific needs.

3 **STAINLESS steel square section stem** completely isolated from the fluid complying with standard ISO 5211:
 DN 40÷65: 11 mm
 DN 80÷100: 14 mm
 DN 125÷150: 17 mm
 DN 200: 22 mm
 DN 250÷300: 27 mm

4 **Body** in polypropylene based **compound reinforced with fiberglass (PP-GR)** **resistant to UV rays** and characterised by **high mechanical strength**.

5 **Drilling pattern using oval slots** that allow coupling to flanges according to numerous international standards. The special **self-centring inserts in ABS** supplied for DN 40÷200 guarantee the **correct axial alignment** of the valve during installation. For DN 250÷400 valves, the drilling pattern for the selfcentring system is of the traditional type according to DIN and ANSI standards.

6 **Interchangeable liner** with the dual function of forming a hydraulic seal and isolating the body from the fluid.

TECHNICAL DATA

PRESSURE VARIATION ACCORDING TO TEMPERATURE

For water and harmless fluids to which the material is classified as CHEMICALLY RESISTANT. In other cases, a reduction of the nominal PN pressure is required (25 years with safety factor). Note: When using PVC-C at working temperatures higher than 90°, it is advisable to first contact the service centre.

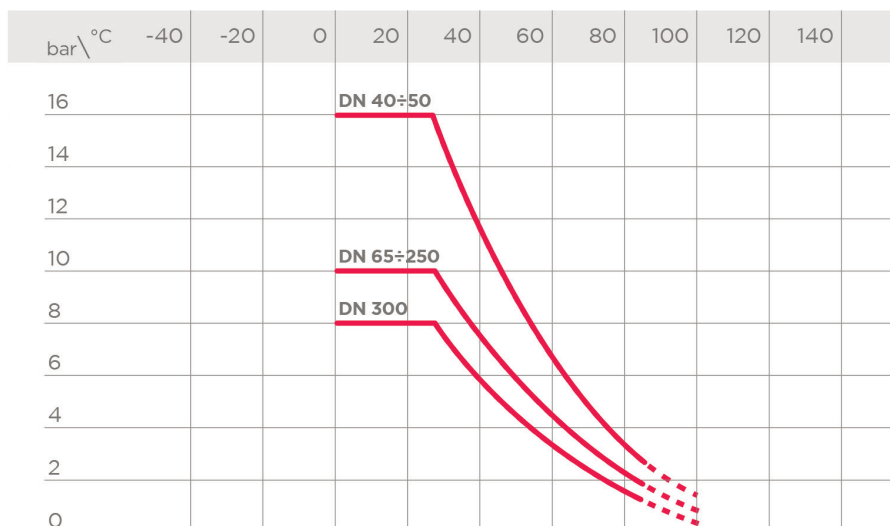

PRESSURE DROP GRAPH

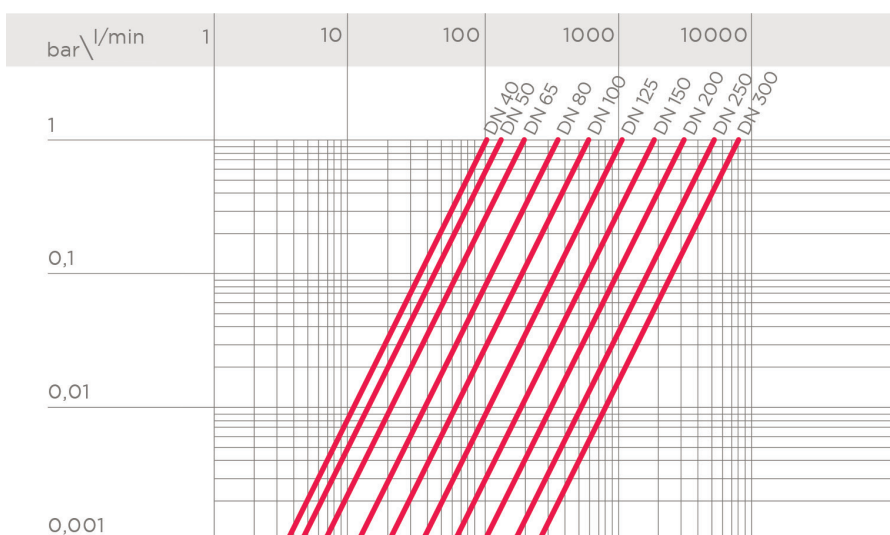

K_v100 FLOW COEFFICIENT

The K_v100 flow coefficient is the Q flow rate of litres per minute of water at a temperature of 20°C that will generate Δp= 1 bar pressure drop at a certain valve position. The Kv100 values shown in the table are calculated with the valve completely open.

DN	40	50	65	80	100	125	150	200	250	300
Kv100 l/min	1000	1285	1700	3550	5900	9850	18700	30500	53200	81600

RELATIVE FLOW COEFFICIENT GRAPH

The relative flow coefficient is the flow rate through the valve as a function of the degree of valve opening.

Horizontal axis: Percentage opening of the disk

Vertical axis: Relative flow coefficient

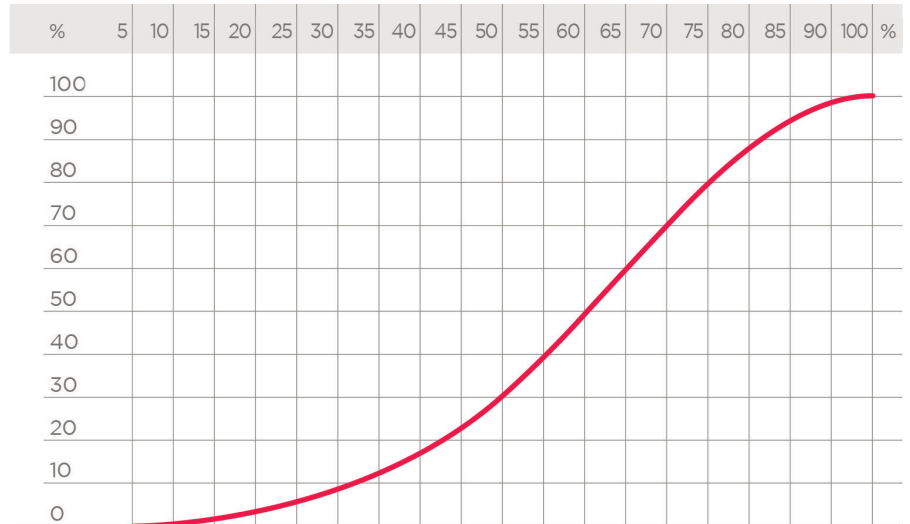

OPERATING TORQUE AT MAXIMUM WORKING PRESSURE

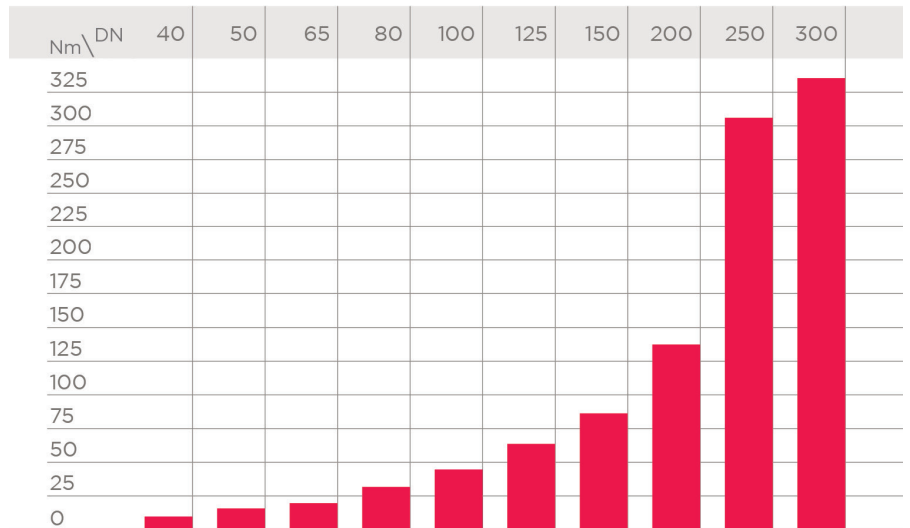

The information in this leaflet is provided in good faith. No liability will be accepted concerning technical data that is not directly covered by recognised international standards. FIP reserves the right to carry out any modification. Products must be installed and maintained by qualified personnel.

DIMENSIONS

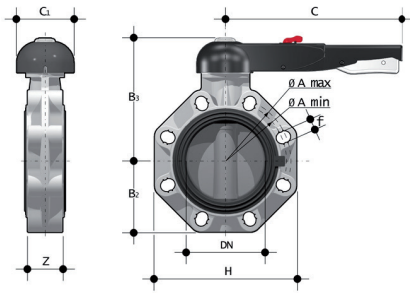

FKOC/LM

Hand operated Butterfly valve

d-Size	DN	PN	A min	A max	B ₂	B ₃	C	C ₁	f	H	U	Z	g	EPDM code	FKM code
50 - 1"1/2	40	16	99	109	60	137	175	100	19	132	4	33	918	FKOCLM050E	FKOCLM050F
63 - 2"	50	16	115	125,5	70	143	175	100	19	147	4	43	1081	FKOCLM063E	FKOCLM063F
75 - 2"1/2	65	10	128	144	80	164	175	110	19	165	4	46	1254	FKOCLM075E	FKOCLM075F
90 - 3"	80	10	145	160	93	178	272	110	19	185	12	49	1987	FKOCLM090E	FKOCLM090F
110 - 4"	100	10	165	190	107	192	272	110	19	211	8	56	2405	FKOCLM110E	FKOCLM110F
140 - 5"	125	10	204	215	120	212	330	110	23	240	8	64	3347	FKOCLM140E	FKOCLM140F
160 - 6"	150	10	230	242	134	225	330	110	23	268	8	70	4212	FKOCLM160E	FKOCLM160F
225 - 8"	200	10	280	298	161	272	420	122	23	323	8	71	7250	FKOCLM225E	FKOCLM225F

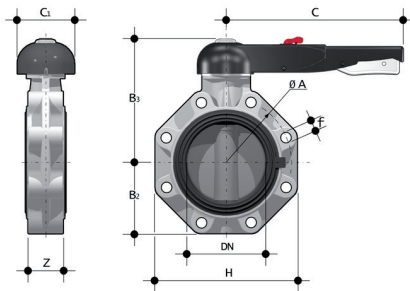

FKOC/LM LUG ISO-DIN

Hand operated Butterfly valve, version Lug ISO-DIN

d	DN	PN	øA	B ₂	B ₃	C	C ₁	f	H	U	Z	g	EPDM code	FKM code
75	65	10	145	80	164	175	110	M16	165	4	46	1554	FKOLCLM075E	FKOLCLM075F
90	80	10	160	93	178	272	100	M16	185	12	49	2342	FKOLCLM090E	FKOLCLM090F
110	100	10	180	107	192	272	110	M16	211	8	56	3257	FKOLCLM110E	FKOLCLM110F
140	125	10	210	120	212	330	110	M16	240	8	64	4345	FKOLCLM140E	FKOLCLM140F
160	150	10	240	134	225	330	110	M20	268	8	70	5820	FKOLCLM160E	FKOLCLM160F
225	200	10	295	161	272	420	122	M20	323	8	71	8896	FKOLCLM225E	FKOLCLM225F

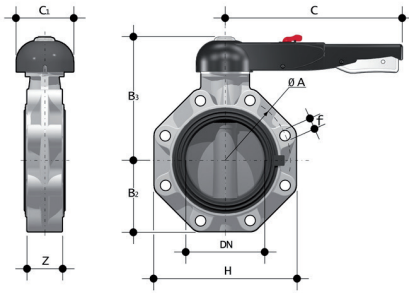

FKOC/LM LUG ANSI

Hand operated Butterfly valve, version Lug ANSI

d	DN	PN	øA	B ₁	B ₂	C	C ₁	f	H	U	Z	g	EPDM code	FKM code
2" 1/2	65	10	139,7	119	80	175	110	5/8"	165	4	46	1554	FKOALCLM212E	FKOALCLM212F
3"	80	10	152,4	133	93	272	110	5/8"	185	12	49	2342	FKOALCLM300E	FKOALCLM300F
4"	100	10	190,5	147	107	272	110	5/8"	211	8	56	3257	FKOALCLM400E	FKOALCLM400F
5"	125	10	215,9	167	120	330	110	3/4"	240	8	64	4345	FKOALCLM500E	FKOALCLM500F
6"	150	10	241,3	180	134	330	110	3/4"	268	8	70	5820	FKOALCLM600E	FKOALCLM600F
8"	200	10	298,4	227	161	420	122	3/4"	323	8	71	8896	FKOALCLM800E	FKOALCLM800F

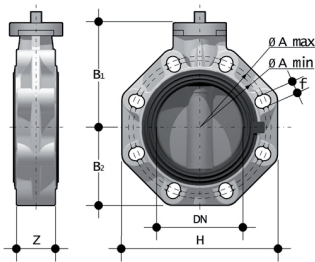

FKOC/FM

Butterfly valve with bare shaft

d - Size	DN	PN	A min	A max	øA	B ₁	B ₂	f	H	U	Z	g	EPDM code	FKM code
50 - 1"1/2	40	16	99	109	-	106	60	19	132	4	33	597	FKOCFM050E	FKOCFM050F
63 - 2"	50	16	115	125,5	-	112	70	19	147	4	43	760	FKOCFM063E	FKOCFM063F
75 - 2"1/2	65	10	128	144	-	119	80	19	165	4	46	933	FKOCFM075E	FKOCFM075F
90 - 3"	80	10	145	160	-	133	93	19	185	12	49	1388	FKOCFM090E	FKOCFM090F
110 - 4"	100	10	165	190	-	147	107	19	211	8	56	1806	FKOCFM110E	FKOCFM110F
140 - 5"	125	10	204	215	-	167	120	23	240	8	64	2659	FKOCFM140E	FKOCFM140F
160 - 6"	150	10	230	242	-	180	134	23	268	8	70	3524	FKOCFM160E	FKOCFM160F
225 - 8"	200	10	280	298	-	227	161	23	323	8	71	6284	FKOCFM225E	FKOCFM225F
280	*250	10	-	-	350	248	210	22	405	12	114	13654	FKOCFM280E	FKOCFM280F
315	*300	8	-	-	400	305	245	29	475	12	114	17931	FKOCFM315E	FKOCFM315F
10"	**250	10	-	-	350	248	210	25,4	405	12	114	13654	FKOACFM810E	FKOACFM810F
12"	**300	8	-	-	400	305	245	25,4	475	12	114	17931	FKOACFM812E	FKOACFM812F

FK suitable for flanged JIS K10 wafer installation is also available on request in the size 10" (DN250)

*ISO-DIN

**ANSI B.16.5 cl.150

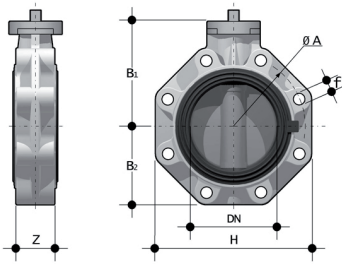

FKOC/FM LUG ISO-DIN

Butterfly valve with bare shaft, version Lug ISO-DIN

d	DN	PN	øA	B ₁	B ₂	f	H	U	Z	g	EPDM code	FKM code
75	65	10	145	119	80	M16	165	4	46	1233	FKOLCFM075E	FKOLCFM075F
90	80	10	160	133	93	M16	185	12	49	1743	FKOLCFM090E	FKOLCFM090F
110	100	10	180	147	107	M16	211	8	56	2658	FKOLCFM110E	FKOLCFM110F
140	125	10	210	167	120	M16	240	8	64	3657	FKOLCFM140E	FKOLCFM140F
160	150	10	240	180	134	M20	268	8	70	5132	FKOLCFM160E	FKOLCFM160F
225	200	10	295	227	161	M20	323	8	71	7930	FKOLCFM225E	FKOLCFM225F
315	300	6	400	305	245	M20	475	12	114	23800	FKOLCFM315E	FKOLCFM315F

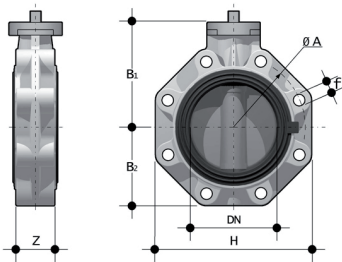

FKOC/FM LUG ANSI

Butterfly valve with bare shaft, version Lug ANSI

d	DN	PN	øA	B ₁	B ₂	f	H	U	Z	g	EPDM code	FKM code
2" 1/2	65	10	139,7	119	80	5/8"	165	4	46	1233	FKOALCFM212E	FKOALCFM212F
3"	80	10	152,4	133	93	5/8"	185	12	49	1743	FKOALCFM300E	FKOALCFM300F
4"	100	10	190,5	147	107	5/8"	211	8	56	2658	FKOALCFM400E	FKOALCFM400F
5"	125	10	215,9	167	120	3/4"	240	8	64	3657	FKOALCFM500E	FKOALCFM500F
6"	150	10	241,3	180	134	3/4"	268	8	70	5132	FKOALCFM600E	FKOALCFM600F
8"	200	10	298,4	227	161	3/4"	323	8	71	7930	FKOALCFM800E	FKOALCFM800F
10"	250	6	362	248	210	7/8"	405	12	114	16800	FKOALCFM810E	FKOALCFM810F
12"	300	6	431,8	305	245	7/8"	475	12	114	23800	FKOALCFM812E	FKOALCFM812F

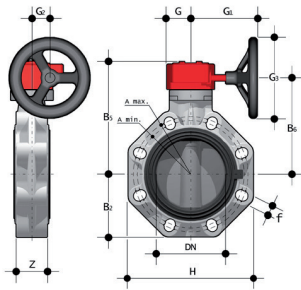

FKOC/RM

Gearbox operated Butterfly valve

d - Size	DN	PN	A min	A max	øA	B ₂	B ₅	B ₆	G	G ₁	G ₂	G ₃	f	H	U	Z	g	EPDM code	FKM code
75 - 2"1/2	65	10	128	144	-	80	174	146	48	135	39	125	19	165	4	46	2608	FKOCRM075E	FKOCRM075F
90 - 3"	80	10	145	160	-	93	188	160	48	135	39	125	19	185	12	49	3063	FKOCRM090E	FKOCRM090F
110 - 4"	100	10	165	190	-	107	202	174	48	135	39	125	19	211	8	56	3481	FKOCRM110E	FKOCRM110F
140 - 5"	125	10	204	215	-	120	222	194	48	144	39	200	23	240	8	64	4434	FKOCRM140E	FKOCRM140F
160 - 6"	150	10	230	242	-	134	235	207	48	144	39	200	23	268	8	70	5299	FKOCRM160E	FKOCRM160F
225	200	10	280	298	-	161	287	256	65	204	60	200	23	323	8	71	8945	FKOCRM225E	FKOCRM225F
250	*250	10	335	362	350	210	317	281	88	236	76	250	22	405	8	114	8945	FKOCRM280E	FKOCRM280F
280	*250	10	335	362	350	210	317	281	88	236	76	250	22	405	8	114	18727	FKOCRM280E	FKOCRM280F
315	*300	8	390	432	400	245	374	338	88	236	76	250	29	475	12	114	23004	FKOCRM315E	FKOCRM315F
10"	**250	10	-	362	350	210	317	281	88	236	-	250	25,4	405	12	114	18727	FKOACRM810E	FKOACRM810F
12"	**300	8	-	431,8	450	245	374	338	88	236	-	250	25,4	475	12	114	23004	FKOACRM812E	FKOACRM812F

FK suitable for flanged JIS K10 wafer installation is also available on request in the size 10" (DN250)
 *ISO-DIN
 **ANSI B.16.5 cl.150

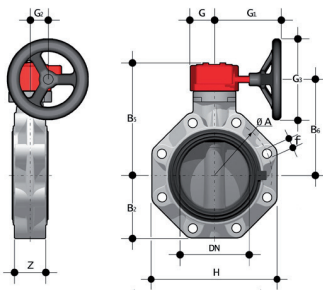

FKOC/RM LUG ISO-DIN

Gearbox operated Butterfly valve, version Lug ISO-DIN

d	DN	PN	øA	B ₂	B ₅	B ₆	f	G	G ₁	G ₂	G ₃	H	U	Z	g	EPDM code	FKM code
75	65	10	145	80	174	146	M16	48	135	39	125	165	4	46	2908	FKOLCRM075E	FKOLCRM075F
90	80	10	160	93	188	160	M16	48	135	39	125	185	12	49	3418	FKOLCRM090E	FKOLCRM090F
110	100	10	180	107	202	174	M16	48	135	39	125	211	8	56	4333	FKOLCRM110E	FKOLCRM110F
140	125	10	210	120	222	194	M16	48	144	39	200	240	8	64	5432	FKOLCRM140E	FKOLCRM140F
160	150	10	240	134	235	207	M20	48	144	39	200	268	8	70	6907	FKOLCRM160E	FKOLCRM160F
225	200	10	295	161	287	256	M20	65	204	60	200	323	8	71	10591	FKOLCRM225E	FKOLCRM225F
315	300	6	400	245	374	338	M20	88	236	76	250	475	12	114	30400	FKOLCRM315E	FKOLCRM315F

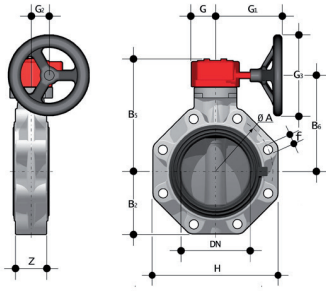

FKOC/RM LUG ANSI

Gearbox operated Butterfly valve, version Lug ANSI

d	DN	PN	øA	B ₁	B ₂	B ₃	f	G	G ₁	G ₂	G ₃	H	U	Z	g	EPDM code	FKM code
2" 1/2	65	10	139,7	80	174	146	5/8"	48	135	39	125	165	4	46	2908	FKOALCRM212E	FKOALCRM212F
3"	80	10	152,4	93	188	160	5/8"	48	135	39	125	185	12	49	3418	FKOALCRM300E	FKOALCRM300F
4"	100	10	190,5	107	202	174	5/8"	48	135	39	125	211	8	56	4333	FKOALCRM400E	FKOALCRM400F
5"	125	10	215,9	120	222	194	3/4"	48	144	39	200	240	8	64	5432	FKOALCRM500E	FKOALCRM500F
6"	150	10	241,3	134	235	207	3/4"	48	144	39	200	268	8	70	6907	FKOALCRM600E	FKOALCRM600F
8"	200	10	298,4	161	287	256	3/4"	65	204	60	200	323	8	71	10591	FKOALCRM800E	FKOALCRM800F
10"	250	6	362	210	317	281	7/8"	88	236	76	250	405	12	114	23400	FKOALCRM810E	FKOALCRM810F
12"	300	6	431,8	245	374	338	7/8"	88	236	76	250	475	12	114	30400	FKOALCRM812E	FKOALCRM812F

ACCESSORIES

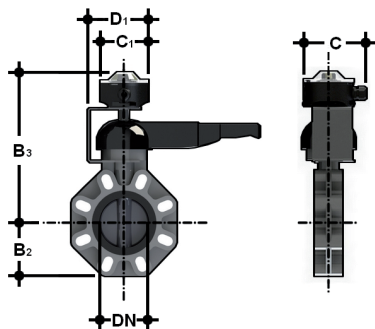

LS Quick Kit

The Limit Switch Quick Kit allows the fast and secure installation of the FIP LSQT module to the FK/LM valves. The kit can be assembled on the valve even if already installed on the system. For technical data of the LSQT box see FIP actuated valves catalogue.

DN	B ₂	B ₃	C	C ₁	D ₁	Code
40	60	260,5	126,9	103	123,5	LSQKITFK5063
50	70	266,5	126,9	103	123,5	LSQKITFK5063
65	80	273,5	126,9	103	123,5	LSQKIT75160
80	93	287,5	126,9	103	123,5	LSQKIT75160
100	107	301,5	126,9	103	123,5	LSQKIT75160
125	120	321,5	126,9	103	123,5	LSQKIT75160
150	134	334,5	126,9	103	123,5	LSQKIT75160
200	161	385	126,9	103	129,8	LSQKIT225



LSE

Customisation and label printing set for Easyfit handle made up of precut adhesive sheets and software for guided label creation.

DN	FE* - FK* code
40	LSE040
50	LSE040
65	LSE040
80	LSE040
100	LSE040
125	LSE040
150	LSE040
200	LSE040

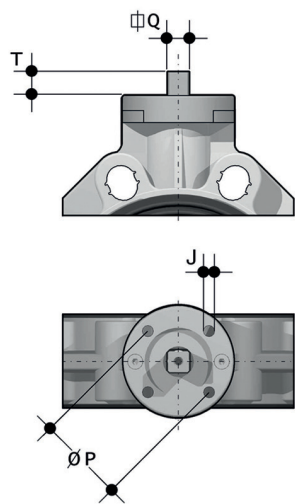

ACTUATOR MOUNTING FLANGE

The valve can be equipped with standard pneumatic or electric actuators and gearbox for heavy-duty operations, using a flange in PP-GR reproducing the drilling pattern provided for by standard ISO 5211.

DN	J	P	Ø	T	Q
40	7	50	F 05	12	11
50	7	50	F 05	12	11
65	7/9	50/70	F 05/F 07	12	11
80	9	70	F 07	16	14
100	9	70	F 07	16	14
125	9	70	F 07	19	17
150	9	70	F 07	19	17
200	11	102	F 10	24	22
200	11	102	F 10	24	22
250	11/13/17	102/125/140	F 10/ F 12/ F 14	29	27
300	11/13/17	102/125/140	F 10/ F 12/ F 14	29	27

CUSTOMISATION

Fig. 1



Fig. 2

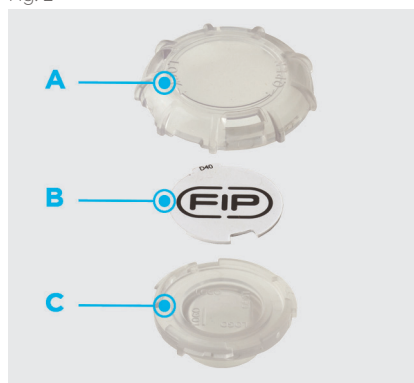

The FK valve is equipped with the customisable Labelling System.

This system lets you create special labels to insert in the handle. This makes it extremely easy to apply company logos, identification serial numbers or service indications such as, for example, the valve function in the system, the transported fluid, but also specific information for customer service, such as the customer name or installation date or location on the valves.

The specific LCE module is a standard supply and is made up of a rigid transparent water-resistant PVC plug (A-C) and white tag holder (B) made of the same material, one side of which bears the FIP logo (fig. 1).

The tag holder, inserted in the plug, can be removed and, once overturned, used for customisation by applying labels printed with the software supplied with the LSE set.

Proceed as follows to apply the label on the valve:

- 1) Remove the upper part of the transparent plug (A) rotating it counter-clockwise as indicated by the word "Open" on the plug and remove it.
- 2) Extract the tag holder from its housing on the lower part of the plug (C).
- 3) Apply the adhesive label on the holder (B) to align the profiles matching the tab position.
- 4) Reinsert the tag holder in its housing at the bottom of the plug.
- 5) Reposition the top of the plug in the housing rotating it clockwise; this way the label is protected against the elements.

COMPONENTS

EXPLODED VIEW DN 40÷65

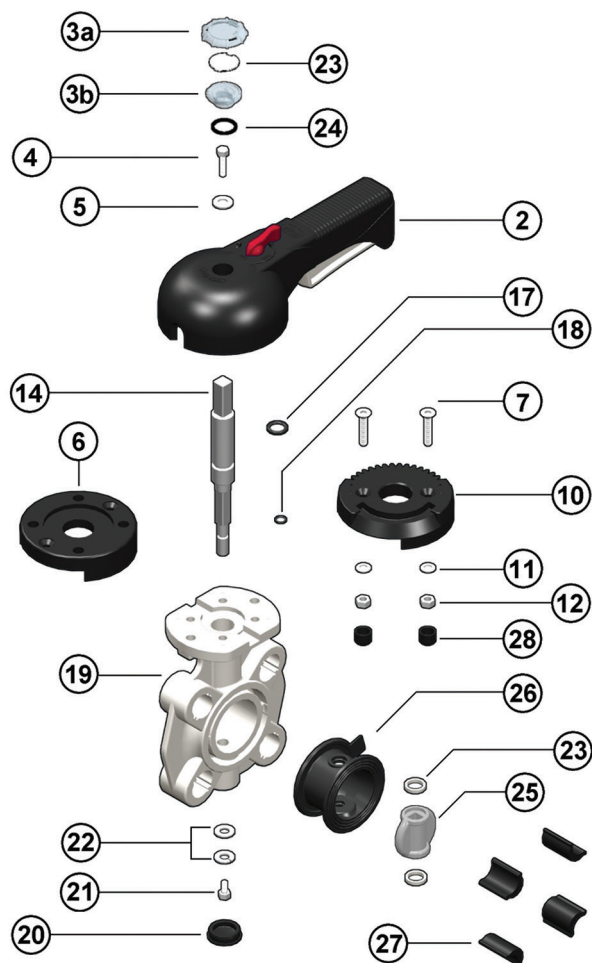

- | | | | | | |
|-------------|---------------------------------------|-----------|--------------------------------|-----------|-------------------------------|
| 1 | Position indicator (PA - 1) | 8 | Tag holder (PVC-U - 1) | 20 | Protection plug (PE - 1) |
| 2 | Handle (HIPVC - 1) | 9 | O-Ring (NBR - 1) | 21 | Screw (STAINLESS steel - 1) |
| 3a/b | Transparent protection plug (PVC - 1) | 10 | Plate (PP-GR - 1) | 22 | Washer (STAINLESS steel - 2) |
| 4 | Fastening screw (STAINLESS steel - 1) | 11 | Washer (STAINLESS steel - 2) | 23 | Anti-friction ring (PTFE - 2) |
| 5 | Washer (STAINLESS steel - 1) | 12 | Nut (STAINLESS steel - 2) | 25 | Disk (PVC-C - 1) |
| 6 | Flange (PP-GR - 1) | 14 | Stem (STAINLESS steel 316 - 1) | 26 | Liner (EPDM o FKM - 1) |
| 7 | Screw (STAINLESS steel - 2) | 17 | Stem O-Ring (EPDM or FKM - 1) | 27 | Inserts (ABS - 4-8) |
| | | 18 | Stem O-Ring (EPDM or FKM - 1) | 28 | Plug (PE - 2) |
| | | 19 | Body (PP-GR - 1) | | |

The component material and quantity supplied are indicated in the parentheses.

EXPLODED VIEW DN 80÷200

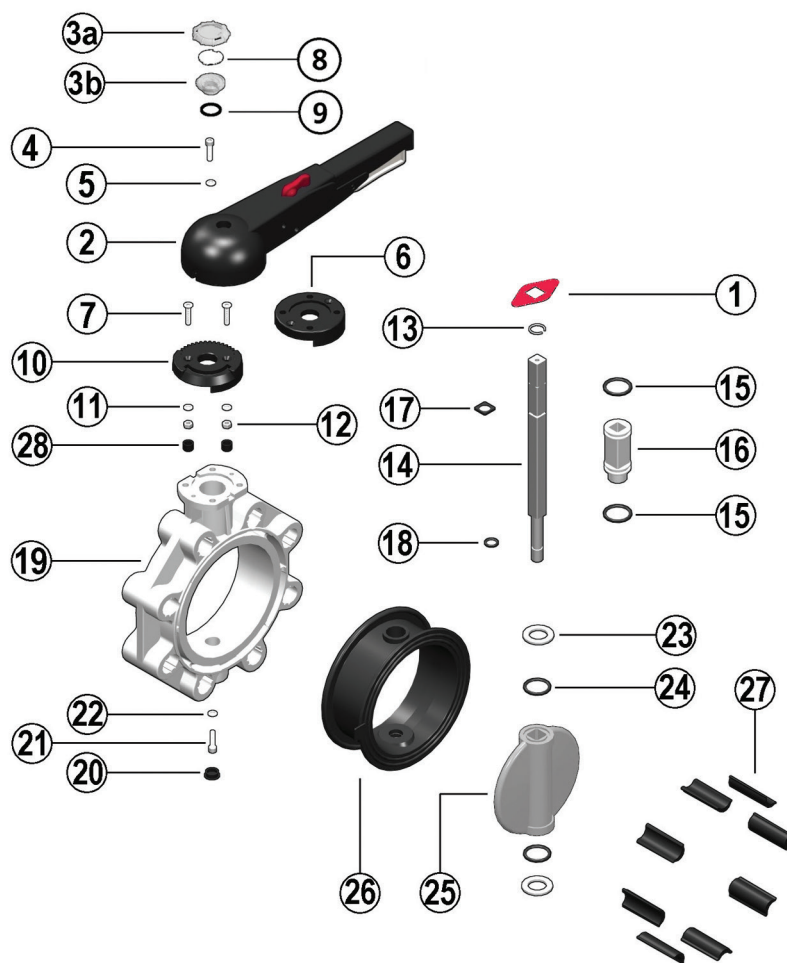

- | | | | | | |
|-------------|---------------------------------------|-----------|-----------------------------------|-----------|-------------------------------|
| 1 | Position indicator (PA - 1) | 9 | O-Ring (NBR - 1) | 19 | Body (PP-GR - 1) |
| 2 | Handle (HIPVC - 1) | 10 | Plate (PP-GR - 1) | 20 | Protection plug (PE - 1) |
| 3a/b | Transparent protection plug (PVC - 1) | 11 | Washer (STAINLESS steel - 2) | 21 | Screw (STAINLESS steel - 1) |
| 4 | Fastening screw (STAINLESS steel - 1) | 12 | Nut (STAINLESS steel - 2) | 22 | Washer (STAINLESS steel - 2) |
| 5 | Washer (STAINLESS steel - 1) | 13 | Seeger ring (STAINLESS steel - 1) | 23 | Anti-friction ring (PTFE - 2) |
| 6 | Flange (PP-GR - 1) | 14 | Stem (STAINLESS steel 316 - 1) | 24 | Disk O-Ring (EPDM or FKM - 2) |
| 7 | Screw (STAINLESS steel - 2) | 15 | Bush O-Ring (EPDM or FKM - 2) | 25 | Disk (PVC-C - 1) |
| 8 | Tag holder (PVC-U - 1) | 16 | Bush (Nylon - 1) | 26 | Liner (EPDM o FKM - 1) |
| | | 17 | Stem O-Ring (EPDM or FKM - 1) | 27 | Inserts (ABS - 4-8) |
| | | 18 | Stem O-Ring (EPDM or FKM - 1) | 28 | Plug (PE - 2) |

The component material and quantity supplied are indicated in the parentheses.

EXPLODED VIEW DN 250÷300

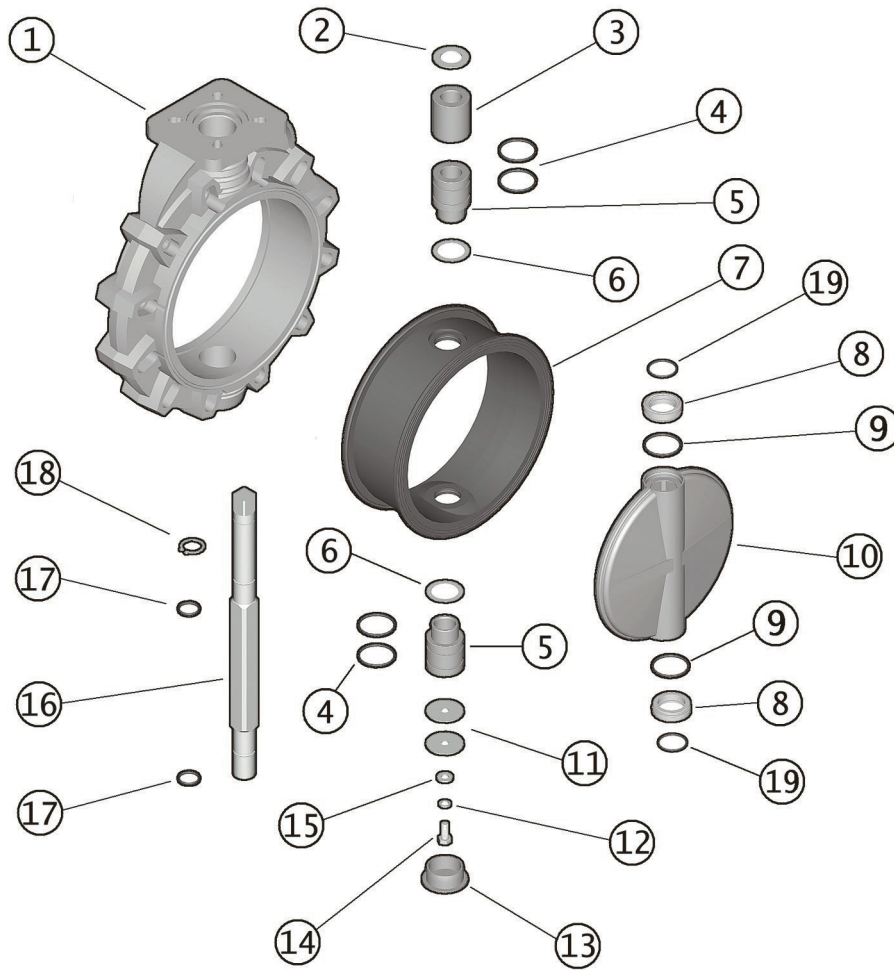

- | | | | | | |
|----------|-------------------------------|-----------|-------------------------------|-----------|-----------------------------------|
| 1 | Body (PP-GR - 1) | 8 | Anti-friction ring (PTFE - 2) | 15 | Washer (STAINLESS steel - 1) |
| 2 | Washer (STAINLESS steel - 1) | 9 | Disk O-Ring (EPDM or FKM - 2) | 16 | Stem (STAINLESS steel - 1) |
| 3 | Bush (PP - 1) | 10 | Disk (PVC-C - 1) | 17 | Stem O-Ring (EPDM or FKM - 2) |
| 4 | Bush O-Ring (EPDM or FKM - 4) | 11 | Washer (STAINLESS steel - 2) | 18 | Seeger ring (STAINLESS steel - 1) |
| 5 | Bush (PP - 2) | 12 | Washer (STAINLESS steel - 1) | 19 | O-Ring (EPDM or FKM - 2) |
| 6 | Washer (PTFE - 2) | 13 | Protection plug (PE - 1) | | |
| 7 | Liner (EPDM or FKM - 1) | 14 | Screw (STAINLESS steel - 1) | | |

The component material and quantity supplied are indicated in the parentheses.

DISASSEMBLY

DN 40÷200

- 1) Remove the LCE module consisting of the rigid transparent PVC plug (3a-3b) and white tag holder (8) and remove screw (2) and washer (3) (fig.3).
- 2) Remove the handle (2).
- 3) Remove the screws (7) and plate (10) from the body (19).
- 4) Remove the protection plug (20) and screw (21) with the washer (22).
- 5) Extract the stem (14) and disk (25).
- 6) Remove the anti-friction rings (23) and (DN 65÷200 only) O-Rings (24).
- 7) Remove the liner (26) from the body (19).
- 8) Remove the Seeger ring (13) and (DN 65÷200 only) guide bush (16).
- 9) Remove (DN 65÷200 only) the O-Rings (15) and (17, 18).

DN 250÷300

- 1) Remove the protection plug (13) and screw (14) with the washers (11-15).
- 2) Extract the stem (16) and disk (10).
- 3) Remove the seal (7) from the body (1).
- 4) Remove the Seeger ring (18) and guide bushes (5-3) with washer (2).
- 5) Extract the lower bush (5).
- 6) Remove O-Rings (4) and (17).

ASSEMBLY

DN 40÷200

- 1) Place the liner (26) on the body (19).
- 2) Insert the O-Rings (17) and (18) on the stem (14).
- 3) Insert the O-Rings (15) on the guide bush (16) and the bush on the stem. Lock the bush using the Seeger ring (13).
- 4) Position the O-Rings (24) and then the anti-friction rings (23) on the disk (25) and the disk inside the body, after having lubricated the liner (26).
- 5) Insert the through stem (14) in the body (19) and disk (25).
- 6) Tighten screw (21) with washer (22) and insert the protection plug (20).
- 7) Position the plate (10) on the body (19) and tighten screws (7).
- 8) Position the handle (2) on the stem (14).
- 9) Tighten screw (4) with washer (5) and replace the LCE module consisting of the rigid transparent PVC plug (3a-3b) and white tag holder (8).

DN 250÷300

- 1) Place the liner (7) on the body (1).
- 2) Insert the O-Rings (4) and washer (6) on bushes (5).
- 3) Insert the O-Rings (17) on the stem (16); insert the upper bush (5), bush (3), washer (2) on the stem and fix them with Seeger ring (18).
- 4) Insert the seals (19-9) on the antifriction rings (8).
- 5) Position the washers (8) in the housings on the disk (10), and the disk inside the body (1) after having lubricated the liner (7).
- 6) Insert the through stem (16) in the body and disk.
- 7) Position the lower bush (5) from below.
- 8) Tighten screws (14) with washers (11-15) and insert the protection plug (13).



Note: during assembly operations, it is advisable to lubricate the rubber seals. Mineral oils are not recommended for this task as they react aggressively with EPDM rubber.

Fig. 3



INSTALLATION

JOINTS

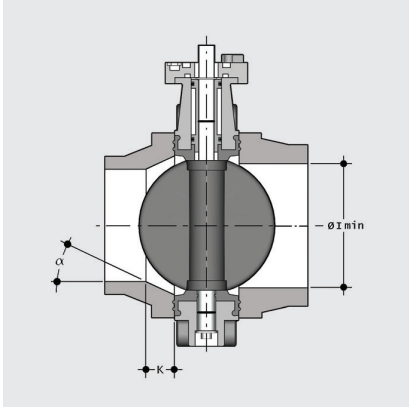

Before proceeding with the installation of the stubs, check that the bore of the fittings has sufficient clearance to allow the valve disk to open correctly. Also check the maximum coupling distance for the liner. Before proceeding with the installation of the FK valve, check that the bore of the stub allows the correct opening of the disk.

DN	l min.
40	25
50	28
65	47
80	64
100	84
125	108
150	134
200	187
250	225
300	280

PP-PE STUBS

For the installation of PP-PE stubs, for butt welding a short spigot or electrofusion/butt welding a long spigot, check the valve-stub-flange couplings and the K - a chamfer dimensions where necessary according to the different SDR's in the following table.

d	DN	50	63	75	90	110	125	140	160	180	200	225	250	280	315
		40	50	65	80	100	100	125	150	150	200	200	250	250	300
50	40														
63	50														
75	65														
90	80														
110	100														
140	125														
160	150														
225	200														
280	250														
315	300														
SDR	17/17,6										k=26,5 a=20°		k=15,7 a=25°		k=13,3 a=25°
	11								k=35 a=20°		k=35 a=25°	k=40 a=15°	k=32,5 a=25°	k=35 a=25°	k=34,5 a=25°
	7,4			k=10 a=35°	k=15 a=35°		k=20 a=30°	k=35 a=20°	k=15 a=35°	k=40 a=20°	k=35 a=30°	k=55 a=30°	k=35 a=30°	k=65 a=30°	

Short/long spigot stubs according to EN ISO 15494

POSITIONING THE INSERTS

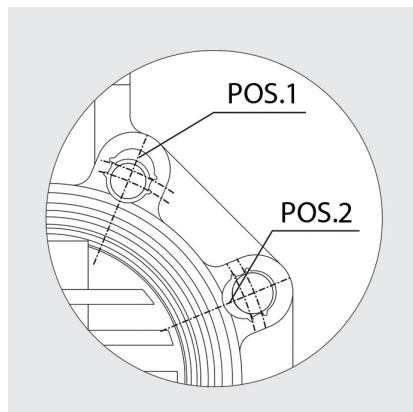

Place the inserts in the holes according to the positions indicated in the table, from the side corresponding to the letters D and DN in order to facilitate the insertion of the stud-bolts and the coupling with the flanges (DN 40 ÷ 200). The self-centring inserts must be inserted in the guides in the slots in the valve body on the side with the writing, with the writing facing upwards, and positioned according to the type of flange drilling, as indicated in the following table:

DN	EN1092-1	EN1092-1, EN ISO15493	BS 10 table A-D-E Spec D-E	ANSI B16.5 cl.150*	JIS B 2220 K5
40	Pos.1	Pos. 2	Pos. 1	Pos. 1	Pos. 1
50	Pos.1	Pos. 2	Pos. 1	-	N/A
65	Pos.1	Pos. 2	Pos. 1	Pos. 2	Pos. 1
80	Pos.1	Pos. 2	Pos. 1	Pos. 2	Pos. 1
100	Pos.1	Pos. 2	Pos. 1	Pos. 2	Pos. 1
125	Pos.1	Pos. 2	Pos. 1	Pos. 2	Pos. 1
150	Pos.1	Pos. 2	Pos. 1	Pos. 2	Pos. 1
200	Pos.1	PN 10 Pos. 2	Pos. 1	Pos. 2	Pos. 1

* DN 50 without inserts

** DN 40, 50, 125 without inserts

POSITIONING THE VALVE

Position the valve between two flanged stubs, taking care to respect the installation tolerances Z. It is advisable to always install the valve with the disk partially closed (it must not exit the body) and avoid any misalignment of the flanges, as this would cause

leaks. Where possible comply with the following requirements:

- Conveying dirty fluids: position the valve with the stem inclined at an angle of 45° to the pipe support plane.
- Conveying fluids with sediment: position the valve with the stem parallel to the pipe support plane.
- Conveying clean fluids: position the valve with the stem perpendicular to the pipe support plane.

JIS FLANGED OPTIONS

FK suitable for flanged JIS K10 wafer installation is also available on request in the size 10" (DN250) and in JIS K5 in the size of 10" (DN250) and 12" (DN300)

TIGHTENING THE STUD-BOLTS

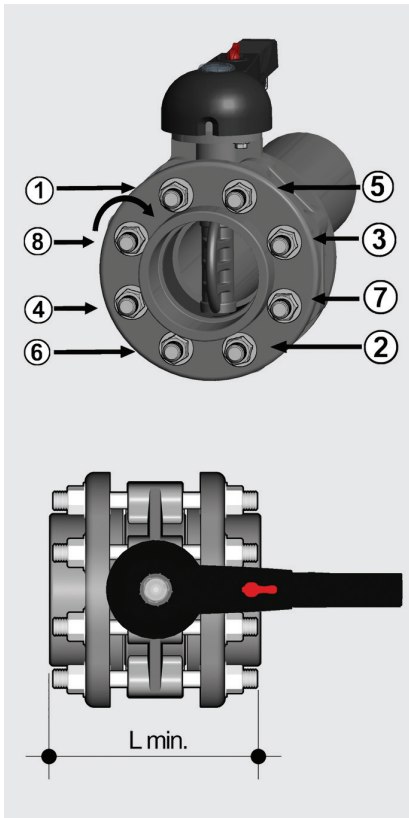

Before tightening the stud-bolts, it is advisable to open the disk in order to prevent damage to the seal. Tighten the stud-bolts in a uniform manner, in the order indicated in the figure, to the nominal operating torque value indicated in the table. The stud-bolts do not need to be excessively tightened in order to produce a perfect hydraulic seal. Overtightening could adversely affect the operating torque of the valve.

DN	L min.	*Nm
40	M16 x 150	9
50	M16 x 150	12
65	M16 x 170	15
80	M16 x 180	18
100	M16 x 180	20
125	M16 x 210	35
150	M20 x 240	40
200	M20 x 260	55
250	M20 x 310	70
300	M20 x 340	70

* Tightening torques for nuts and bolts on couplings with backing rings.

Values required to obtain the hydraulic test seal (1.5xPN at 20°C) (new or lubricated nuts and bolts)

HANDLE LOCK



Thanks to the multifunctional handle and the red manoeuvre button on the lever, you can perform a 0°-90° operation and a graduated operation by means of the 10 intermediate positions and a stop lock: the handle can be locked in each of the 10 positions by simply pressing the Free-lock button. A lock can also be installed on the handle to protect the system against tampering. The valve is two-way and can be installed in any position. It can also be installed at end line or tank.

WARNINGS

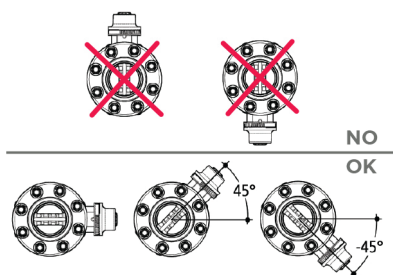

Make sure that the valves installed on the system are suitably supported for their weight.

Always avoid sudden closing manoeuvres and protect the valve from accidental operations. To this end, it is advisable to install a reduction gear, available on request.

In the case of dirty fluids or those with sediments, install the valve inclined as shown in the figure.