

GBM/GKM PN6 SDR 17,6 - S 8,3 - Curva a 90° estremità uguali

Curva a 90° codolo corto per saldatura di testa PN6 SDR 17,6 - S 8,3.

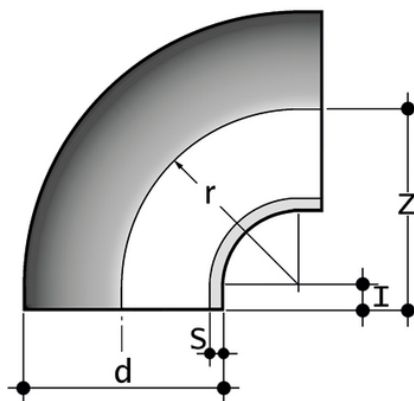

Codice	d	l	r	s	Z	g
GBM17125	125	15	125	7,1	140	652
GBM17140	140	15	140	8,0	155	900
GBM17160	160	15	160	9,1	175	1231
GBM17180	180	15	180	10,2	195	1875
GBM17200	200	15	200	11,4	215	2423
GBM17225	225	20	225	13,4	245	3469
GBM17250	250	25	250	14,2	275	4568
GBM17280	280	30	280	15,9	310	6550
GBM17315	315	35	315	17,9	350	9728
GBM17355	*355	38	355	20,1	385	12760
GBM17400	*400	41	400	22,7	438	18500
GBM17450	*450	60	450	25,5	510	40800
GBM17500	*500	60	500	28,3	560	52150
GKM17050	50	23	36	2,9	62	48,7
GKM17063	63	21	65	3,6	77	101,1
GKM17075	75	21	75	4,3	85	137,7
GKM17090	90	22	90	5,1	100	234
GKM17110	110	25	110	6,3	120	412