

## Q/BBE-L - Union end

Union end, long spigot, for butt welding SDR 11 - S5.

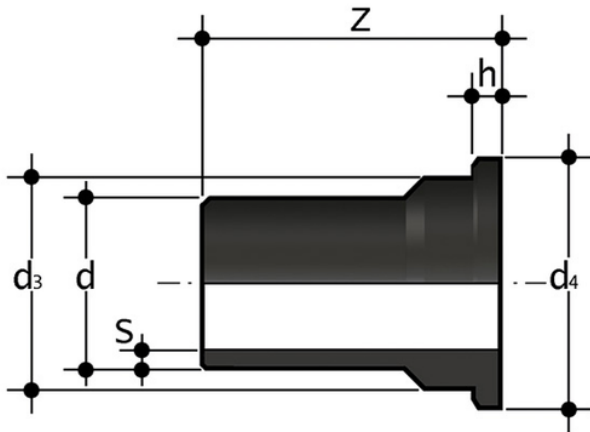

Codice	d	L	h	d <sub>3</sub>	d <sub>4</sub>	S	g
QBBEL11020	20	94	5	27,30	29,90	1,9	22
QBBEL11025	25	95	6	35,80	38,60	2,3	38
QBBEL11032	32	95	6	41,20	44,50	2,9	44
QBBEL11040	40	95	7	52,60	56,20	3,7	73
QBBEL11050	50	95	7	58,60	62,30	4,6	107
QBBEL11063	63	95	8	73,60	78,10	5,8	165

## Q/BBE-L - Union end

- Size range: d 12 ÷ d 800 (mm)
- Nominal pressure: SDR 17 (PN10) with water at 20 °C, SDR 11 (PN16) with water at 20 °C
- Temperature range: -40 °C ÷ 60 °C
- Coupling standards - Reference standards:
  - Welding: EN ISO 15494. Can be coupled to pipes according to EN ISO 15494
  - Flanging system: ISO 7005-1, EN 1092-1, EN ISO 15494, ANSI B16.5 cl.150
  - Construction criteria: UNI EN ISO 15494
  - Test methods and requirements: UNI EN ISO 15494
  - Installation criteria: DVS 2202-1, DVS 2207-1, UNI EN 12201- 3, UNI 10520, ISO 21307, UNI 10521, UNI EN 1555-3, ISO 4427- 3, ISO 4437-3
- Fitting material: PE-HD
- Seal material: EPDM, FKM