

# BBE-L SDR 11 - Complete union

Complete union, longspigot, for butt welding with EPDM or FKM O-ring SDR 11 - S5.

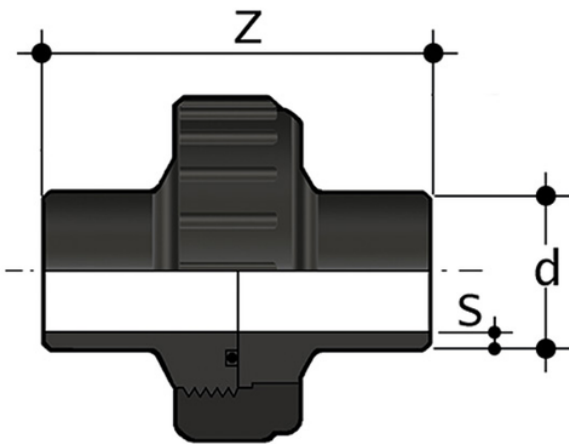

## EPDM

Codice	d	Z	S	g
BBEL11020E	20	190	1,9	68
BBEL11025E	25	190	2,3	107
BBEL11032E	32	190	2,9	140
BBEL11040E	40	190	3,7	214
BBEL11050E	50	190	4,6	299
BBEL11063E	63	190	5,8	491

## FKM

Codice	d	Z	S	g
BBEL11020F	20	190	1,9	68
BBEL11025F	25	190	2,3	107
BBEL11032F	32	190	2,9	140
BBEL11040F	40	190	3,7	214
BBEL11050F	50	190	4,6	299
BBEL11063F	63	190	5,8	491

## BBE-L SDR 11 – Complete union

- Size range: d 12 ÷ d 800 (mm)
- Nominal pressure: SDR 11 (PN16) with water at 20 °C
- Temperature range: -40 °C ÷ 60 °C
- Coupling standards – Reference standards:
  - Welding: EN ISO 15494. Can be coupled to pipes according to EN ISO 15494
  - Flanging system: ISO 7005-1, EN 1092-1, EN ISO 15494, ANSI B16.5 cl.150
  - Construction criteria: UNI EN ISO 15494
  - Test methods and requirements: UNI EN ISO 15494
  - Installation criteria: DVS 2202-1, DVS 2207-1, UNI EN 12201- 3, UNI 10520, ISO 21307, UNI 10521, UNI EN 1555-3, ISO 4427- 3, ISO 4437-3
- Fitting material: PE-HD
- Seal material: EPDM, FKM