

# TBE SDR17 - 90° Tee

90° Tee, short spigot for butt welding SDR 17 - S8.

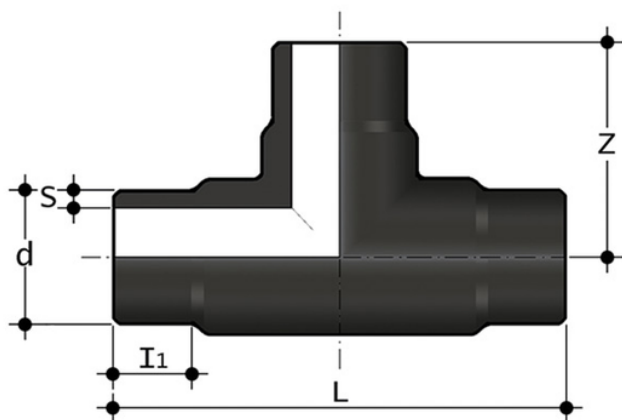

| Codice   | d    | L   | Z   | h <sub>1</sub> | S    | g      |
|----------|------|-----|-----|----------------|------|--------|
| TBE17050 | *50  | 100 | 50  | 13             | 3,0  | 86     |
| TBE17063 | 63   | 156 | 78  | 29             | 3,8  | 182    |
| TBE17075 | 75   | 180 | 90  | 33             | 4,5  | 310    |
| TBE17090 | 90   | 200 | 100 | 23             | 5,4  | 513    |
| TBE17110 | 110  | 240 | 120 | 43             | 6,6  | 840    |
| TBE17125 | 125  | 250 | 125 | 26             | 7,4  | 1170   |
| TBE17140 | 140  | 280 | 140 | 32             | 8,3  | 1635   |
| TBE17160 | 160  | 350 | 160 | 40             | 9,5  | 2402   |
| TBE17180 | 180  | 390 | 195 | 73             | 10,7 | 3503   |
| TBE17225 | 225  | 490 | 245 | 72             | 13,4 | 7417   |
| TBE17250 | *250 | 450 | 225 | 67             | 14,8 | 7670   |
| TBE17280 | *280 | 528 | 264 | 86             | 16,6 | 10,900 |
| TBE17315 | *315 | 565 | 282 | 87             | 18,7 | 14,900 |
| TBE17355 | *355 | 699 | 348 | 103            | 21,1 | 23640  |
| TBE17400 | *400 | 722 | 361 | 105            | 23,7 | 28500  |
| TBE17450 | *450 | 838 | 419 | 137            | 26,7 | 47500  |
| TBE17500 | *500 | 940 | 471 | 163            | 29,7 | 53500  |

## TBE SDR17 - 90° Tee

- Size range: d 12 ÷ d 800 (mm)
- Nominal pressure: SDR 17 (PN10) with water at 20 °C, SDR 11 (PN16) with water at 20 °C
- Temperature range: -40 °C ÷ 60 °C
- Coupling standards - Reference standards:
  - Welding: EN ISO 15494. Can be coupled to pipes according to EN ISO 15494
  - Flanging system: ISO 7005-1, EN 1092-1, EN ISO 15494, ANSI B16.5 cl.150
  - Construction criteria: UNI EN ISO 15494
  - Test methods and requirements: UNI EN ISO 15494
  - Installation criteria: DVS 2202-1, DVS 2207-1, UNI EN 12201- 3, UNI 10520, ISO 21307, UNI 10521, UNI EN 1555-3, ISO 4427- 3, ISO 4437-3
- Fitting material: PE-HD
- Seal material: EPDM, FKM