

SSELV/A316 – Easyfit True Union ball and spring check valve DN 10:50

Easyfit spring check valve with female ends for solvent welding, BS series. A316 spring.

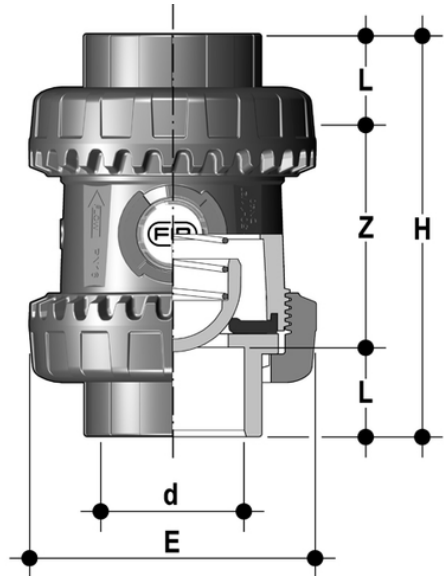

EPDM

Reference	d	DN	PN	E	H	L	Z	g
SSELV038E	3/8"	10	16	54	78	14,5	49	154
SSELV012E	1/2"	15	16	54	82	16,5	49	149
SSELV034E	3/4"	20	16	63	91	19	53	188
SSELV100E	1"	25	16	72	103	22,5	58	292
SSELV114E	1" 1/4	32	16	85	120	26	68	445
SSELV112E	1" 1/2	40	16	100	139	30	79	640
SSELV200E	2"	50	16	118	174	36	102	1010

FKM

Reference	d	DN	PN	E	H	L	Z	g
SSELV038F	3/8"	10	16	54	78	14,5	49	154
SSELV012F	1/2"	15	16	54	82	16,5	49	149
SSELV034F	3/4"	20	16	63	91	19	53	188
SSELV100F	1"	25	16	72	103	22,5	58	292
SSELV114F	1" 1/4	32	16	85	120	26	68	445
SSELV112F	1" 1/2	40	16	100	139	30	79	640
SSELV200F	2"	50	16	118	174	36	102	1010

SSELV/A316 – Easyfit True Union ball and spring check valve DN 10:50

- **Customisable Labelling System: built-in LCE module** on the valve body made up of transparent protection plug and customisable tag holder using the LSE set (available as accessory). The customisation potential lets you identify the valve on the system according to specific needs.
- **Optimised dynamic fluid design:** energy savings thanks to the improved valve Kv value with consequent pressure drop reduction
- High surface finish ball shutter: **wear reduction**, increase in working life and reduced valve maintenance. Ideal for conveying dirty fluids, even with suspended solids and filaments thanks to the special design that permits **internal valve selfcleaning**
- **Locked ball seat carrier:** safe dismounting for maintenance with the Easyfit multifunctional handle or Easytorque kit
- Ideal for horizontal installations: **perfect seal even with low back pressure. Silent** and durable even with strong vibrations and pulsating fluid
- PVC-U shutter and springs available made of STAINLESS steel 316, Hastelloy C276, A316 PTFE encapsulated: maximum reliability in a **wide field of applications** from salt water to aggressive acids
- Connection system for solvent weld and threaded joints
- **Valve material compatibility (PVC-U)** with water conveyance, drinking water and other food substances according to current regulations
- **PN16 True Union** valve body made for PVC-U injection moulding and European Directive 2014/68/EU (PED) compliant for pressurised equipment. ISO 9393 compliant test requirements
- **Short face to face dimension** according to international regulation ISO 7508 series III and European regulation EN 1452 "short" and fully interchangeable with VXE and VEE DN 10÷50 ball valve models
- Union nuts with rack for tightening adjustment via Easyfit handle or via Easytorque adjustment kit (available as accessories)
- **Vertical** (preferable for SXE model) and **horizontal installation** potential