

# TIM - Fitting for socket welding, Tee

90° Tee for socket welding, equal socket.

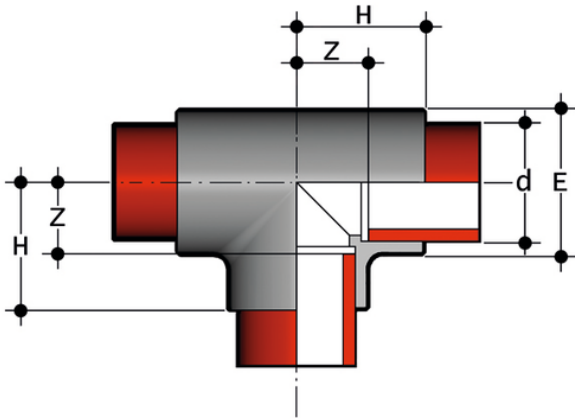

Reference	d	DN	PN	E	H	Z	g
TIM020	20	15	10	28	28	13	19
TIM025	25	20	10	34	32	16	30
TIM032	32	25	10	42	37	19	47
TIM040	40	32	10	52	43	23	80
TIM050	50	40	10	64	52	29	145
TIM063	63	50	10	80	63	35	250
TIM075	75	65	10	93	71	40	370
TIM090	90	80	10	111	82	46	560
TIM110	110	100	10	135	100	58	990