

GBM/GKM PN10 SDR 11 - S 5 - 90° bend equal ends

90° bend, short spigot for butt welding PN10 SDR 11 - S 5.

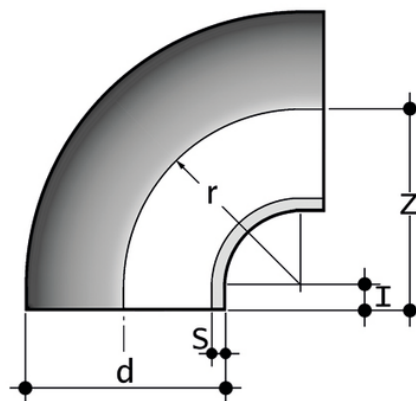

Reference	d	l	r	s	Z	g
GBM11125	125	15	125	11,4	140	945
GBM11140	140	15	140	12,7	155	1300
GBM11160	160	15	160	14,6	175	1870
GBM11180	180	15	180	16,4	195	2767
GBM11200	200	15	200	18,2	215	3604
GBM11225	225	20	225	20,5	245	5292
GBM11250	250	25	250	22,7	275	7210
GBM11280	280	30	280	25,4	310	10020
GBM11315	315	35	315	28,6	350	13965
GBM11355	*355	38	355	32,2	385	19365
GBM11400	*400	41	400	36,3	438	28650
GBM11450	*450	60	450	40,9	510	52551
GBM11500	*500	60	500	45,4	560	67410
GKM11020	20	20	18	1,9	34	6,9
GKM11025	25	20	18	2,3	37	11
GKM11032	32	21	20	2,9	40	19,1
GKM11040	40	22	35	3,7	51	37,4
GKM11050	50	23	36	4,6	62	70
GKM11063	63	21	65	5,8	77	139,5
GKM11075	75	21	75	6,8	85	199,6



GBM/GKM PN10 SDR 11 - S 5 - 90° bend equal ends

Reference	d	l	r	s	Z	g
GKM11090	90	22	90	8,2	100	341,1
GKM11110	110	25	110	10,0	120	598,9