

# BBM-L SDR 11 - Union

Long spigot union for butt welding with seal in EPDM or FKM PN10 SDR 11 - S5.

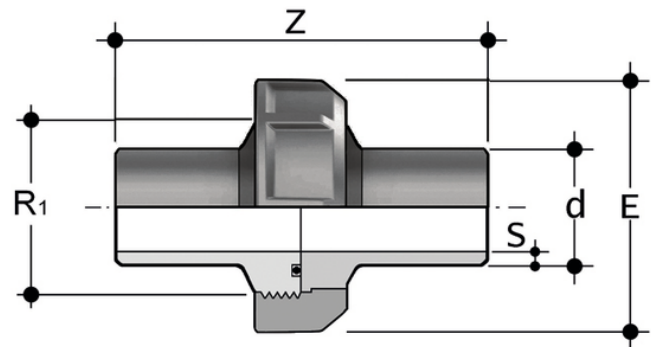

## \*EPDM

Reference	d	DN	R <sub>1</sub>	E	s	Z	g
BBML11020E	20	15	1"	46	1,9	190	70
BBML11025E	25	20	1 1/4"	56	2,3	190	105
BBML11032E	32	25	1 1/2"	66	2,9	190	140
BBML11040E	40	32	2"	79	3,7	190	210
BBML11050E	50	40	2 1/4"	87	4,6	190	295
BBML11063E	63	50	2 3/4"	107	5,8	190	480

## \*\*FKM

Reference	d	DN	R <sub>1</sub>	E	s	Z	g
BBML11020F	20	15	1"	46	1,9	190	70
BBML11025F	25	20	1 1/4"	56	2,3	190	105
BBML11032F	32	25	1 1/2"	66	2,9	190	140
BBML11040F	40	32	2"	79	3,7	190	210
BBML11050F	40	50	2 1/4"	87	4,6	190	295
BBML11063F	63	50	2 3/4"	107	5,8	190	480