

# TIF

90° Tee for socket welding.

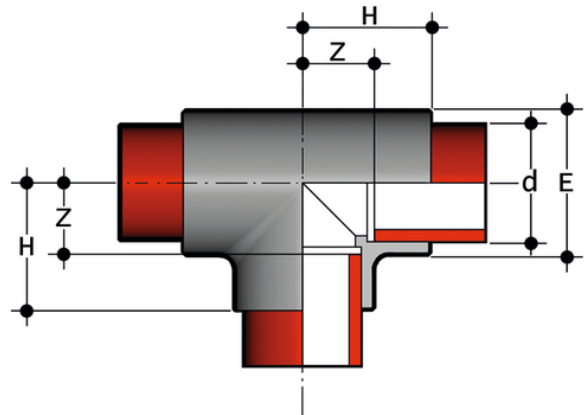

Reference	d	PN	E	H	Z	g
TIF016	16	16	22	23	10	18
TIF020	20	16	28	27	13	35
TIF025	25	16	33	32	16	55
TIF032	32	16	41	37	19	90
TIF040	40	16	51	43	22	150
TIF050	50	16	63	52	29	270
TIF063	63	16	79	63	35	470
TIF075	75	16	93	71	40	665
TIF090	90	16	109	82	46	1025
TIF110	110	16	133	99	58	1800