

# DKDDV/CP NO – Pneumatically actuated 2-way diaphragm valve PN6 DN 15:65

Pneumatically actuated diaphragm valve with metric spigot ends for solvent welding, Normally Open, Direct Acting.

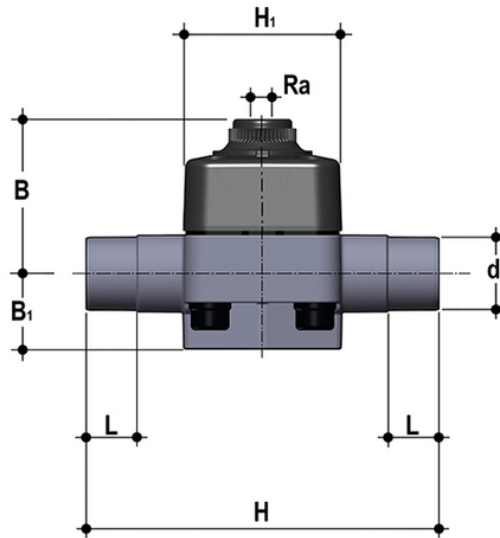

Reference	d	DN	PN	B	B <sub>1</sub>	H	h	H <sub>1</sub>	L	R <sub>a</sub>	g
DKDDVNO020E	20	15	8	58	25	124	12	65	16	1/4"	270
DKDDVNO025E	25	20	8	61	29,5	144	12	65	19	1/4"	292
DKDDVNO032E	32	25	8	70	33	154,5	12	70	22	1/4"	492
DKDDVNO040E	40	32	8	72	30	174,5	12	70	26	1/4"	536
DKDDVNO050E	50	40	8	87	35	195,5	16	99	31	1/4"	1100
DKDDVNO063E	63	50	8	109	46	225	16	114	38	1/4"	1924
DKDDVNO075E	75	65	8	109	46	284	16	114	44	1/4"	2045

# DKDDV/CP NO – Pneumatically actuated 2-way diaphragm valve PN6 DN 15:65

The valve comprises three elements: body, diaphragm and sealing bonnet. Due to the action of the compressed air in the bonnet, the diaphragm is pressed against the body saddle interrupting the flow. This simplified operating principle and the lower number of components guarantees high reliability and durability.

- PP-GR sealing bonnet marked by high construction strength. The absence of metal parts exposed to the external environment prevents any risk of corrosion.
- The special sealing diaphragm reinforced with textile fibres allows longer operation to be reached without showing any signs of wear.
- New valve body internal design. Substantially higher flow coefficient and lower pressure drops. The degree of efficiency reached has also enabled the size and weight of the valve to be reduced.
- Connection system using solvent welded and threaded joints
- Optimised fluid dynamic design: maximum output flow rate thanks to the optimised efficiency of the fluid dynamics that characterise the new internal geometry of the body
- In the Standard version, equipped with textile fibre reinforced diaphragm
- Bonnet fastening screws in STAINLESS steel protected against the external environment by PE plugs
- Easy to clean valve interior
- Low risk of the accumulation of deposits, contamination or damage to the diaphragm due to crystallisation
- Easy to replace diaphragm seal.