

# DKBOAV/CP NC - Pneumatically actuated 2-way diaphragm valve PN6 DN 15:65

Pneumatically actuated diaphragm valve with flanged monolithic body, drilled ANSI B16.5 cl. 150 #FF. Normally Closed function.

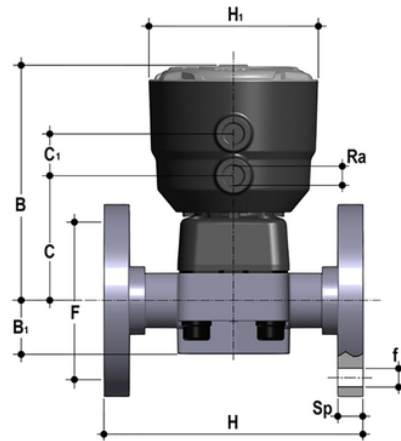

Reference	d	DN	PN	B	B <sub>1</sub>	C	C[5:1]	F	f	H	H <sub>1</sub>	R <sub>a</sub>	U	Sp	g
DKBOAVNC012E	1/2"	15	6	134	25	66	24	60,30	14	108	97	1/4"	4	13,5	875
DKBOAVNC034E	3/4"	20	6	137	30	69	24	69,90	15,7	120	97	1/4"	4	13,5	955
DKBOAVNC100E	1"	25	6	145	33	78	24	79,40	15,7	131	97	1/4"	4	13,5	1221
DKBOAVNC112E	1" 1/2	40	6	193	35	112	24	98,40	15,7	180	126	1/4"	4	16	3136
DKBOAVNC114E	1" 1/4	32	6	149	30	82	24	88,90	15,7	162	97	1/4"	4	14	1411
DKBOAVNC200E	2"	50	6	231	46	142	24	120,70	19	210	157	1/4"	4	16	6351
DKBOAVNC212E	2" 1/2	65	6	231	46	142	24	139,70	19	250	157	1/4"	4	21	6952

# DKBOAV/CP NC – Pneumatically actuated 2-way diaphragm valve

## PN6 DN 15:65

The new DKB/CP diaphragm valve has a piston actuator in PP-GR with a simplified design, ensuring essential performance.

- Compact and light piston in PP-GR, ideal for heavy-duty applications in chemically aggressive environments with a diaphragm perimeter containment system that ensures the perfect compression of the rubber without any lateral expansion.
- Piston in high strength IXEF<sup>®</sup>. The high quality finishing of the external surface guarantees perfect slidability over the seal and ensures a long working life without any actuator maintenance.
- High strength stainless steel stem with double seal O-Ring. Floating pin connection between the actuator stem and diaphragm to prevent concentrated loads, improve the seal and extend its lifetime.
- Actuator equipped with 4 independent cartridge springs arranged radially to uniformly distribute the load on the piston.
- Dual function main gasket. Piston seal: the gasket does not move but sits securely on the actuator cylinder instead of the piston. External seal: the gasket positioned above the threaded joint between the bonnet and cylinder ensures that the coupling is not stressed by the pressure inside the actuator.
- Easy installation in confined spaces: compressed air inlets with G 1/4" threaded adjustable connections to enable alignment with the piping. PP-GR connections prevent any risk of corrosion.
- New valve body internal design. Substantially higher flow coefficient and lower pressure drops. The degree of efficiency reached has also enabled the size and weight of the valve to be reduced. Adjustment linearity: the internal profiles of the valve greatly improve its characteristic curve, allowing extremely sensitive and precise adjustment along the entire length of the shutter stroke.
- Connection system for solvent weld, threaded and flanged joints
- Optimised fluid dynamic design: maximum output flow rate thanks to the optimised efficiency of the fluid dynamics that characterise the new internal geometry of the body
- Bonnet fastening screws in Stainless Steel protected against the external environment by PE plugs. Absence of metal parts exposed to the external environment to prevent any risk of corrosion
- New flanged bodies: the new bodies, characterised by a monolithic flanged structure, are available in PVC-U, PVC-C and PP-H materials. This design, free of joints between body and flanges, considerably reduces mechanical stress and increases system performance
- CDSA seal system (Circular Diaphragm Sealing Angle) with a uniform distribution of the shutter pressure on the sealing membrane offers the following advantages:
  - Operating torque reduction.
  - Reduced mechanical stress on all valve components (actuator, body and diaphragm).
  - Low risk of the accumulation of deposits, contamination or damage to the diaphragm due to crystallisation.
  - Easy to clean valve interior