

# DKUAC/CP NO – Pneumatically actuated 2-way diaphragm valve PN 10 DN 15:65

Pneumatically actuated diaphragm valve with female union ends for solvent welding, ASTM series Normally Open function.

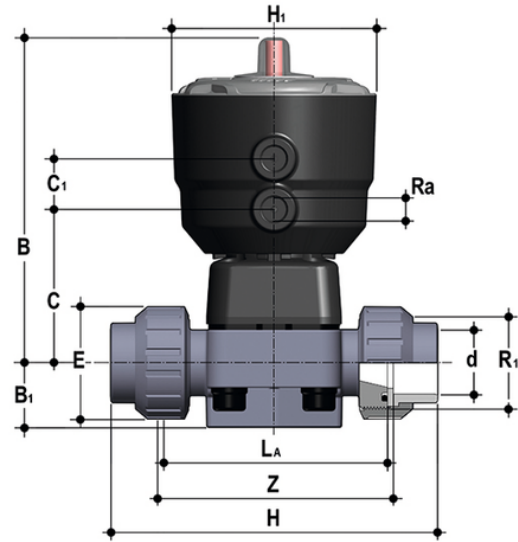

## EPDM

Reference	R	DN	PN	B	B <sub>1</sub>	C	C <sub>1</sub>	E	H	H <sub>1</sub>	L[5:α]	R <sub>1</sub>	R[5:α]	Z	g
DKUACNO012E	1/2"	15	10	148	25	66	24	41	143	97	90	1"	1/4"	98	744
DKUACNO034E	3/4"	20	10	151	30	69	24	50	167	97	108	1 1/4"	1/4"	115	811
DKUACNO100E	1"	25	10	159	33	78	24	58	180	97	116	1 1/2"	1/4"	122	1047
DKUACNO114E	1 1/4"	32	10	163	30	82	24	72	208	97	134	2"	1/4"	144	1180
DKUACNO112E	1 1/2"	40	10	207	35	112	24	79	234	126	154	2 1/2"	1/4"	164	2508
DKUACNO200E	2"	50	10	245	46	142	24	98	272	157	184	2 3/4"	1/4"	195	4606

## FKM

Reference	R	DN	PN	B	B <sub>1</sub>	C	C <sub>1</sub>	E	H	H <sub>1</sub>	L[5:α]	R <sub>1</sub>	R[5:α]	Z	g
DKUACNO012F	1/2"	15	10	148	25	66	24	41	143	97	90	1"	1/4"	98	744
DKUACNO034F	3/4"	20	10	151	30	69	24	50	167	97	108	1 1/4"	1/4"	115	811
DKUACNO100F	1"	25	10	159	33	78	24	58	180	97	116	1 1/2"	1/4"	122	1047
DKUACNO114F	1 1/4"	32	10	163	30	82	24	72	208	97	134	2"	1/4"	144	1180
DKUACNO112F	1 1/2"	40	10	207	35	112	24	79	234	126	154	2 1/2"	1/4"	164	2508
DKUACNO200F	2"	50	10	245	46	142	24	98	272	157	184	2 3/4"	1/4"	195	4606

## PTFE



# DKUAC/CP NO – Pneumatically actuated 2-way diaphragm valve PN 10 DN 15:65

Reference	R	DN	PN	B	B <sub>1</sub>	C	C <sub>1</sub>	E	H	H <sub>1</sub>	L[5:a]	R <sub>1</sub>	R[5:a]	Z	g
DKUACNO012P	1/2"	15	10	148	25	66	24	41	143	97	90	1"	1/4"	98	744
DKUACNO034P	3/4"	20	10	151	30	69	24	50	167	97	108	1"1/4	1/4"	115	811
DKUACNO100P	1"	25	10	159	33	78	24	58	180	97	116	1"1/2	1/4"	122	1047
DKUACNO114P	1"1/4	32	10	163	30	82	24	72	208	97	134	2"	1/4"	144	1180
DKUACNO112P	1"1/2	40	10	207	35	112	24	79	234	126	154	2"1/2	1/4"	164	2508
DKUACNO200P	2"	50	10	245	46	142	24	98	272	157	184	2"3/4	1/4"	195	4606



# DKUAC/CP NO – Pneumatically actuated 2-way diaphragm valve PN 10 DN 15:65

The new compact and light piston actuator in PP-GR makes the DK/CP the ideal choice for applications requiring very frequent valve operation and a long valve lifetime.

- High visibility graduated optical position indicator protected by a transparent cap with a seal O-Ring.
- Compact and light piston in PP-GR, ideal for heavy-duty applications in chemically aggressive environments with a diaphragm perimeter containment system that ensures the perfect compression of the rubber without any lateral expansion.
- Piston in high strength IXEF<sup>®</sup>. The high quality finishing of the external surface guarantees perfect slidability over the seal and ensures a long working life without any actuator maintenance.
- High strength stainless steel stem with double seal O-Ring. Floating pin connection between the actuator stem and diaphragm to prevent concentrated loads, improve the seal and extend its lifetime.
- Actuator equipped with 6 independent cartridge springs arranged radially to uniformly distribute the load on the piston.
- Dual function main gasket. Piston seal: the gasket does not move but sits securely on the actuator cylinder instead of the piston. External seal: the gasket positioned above the threaded joint between the bonnet and cylinder ensures that the coupling is not stressed by the pressure inside the actuator.
- Easy installation in confined spaces: compressed air inlets with G 1/4" threaded adjustable connections to enable alignment with the piping. PPGR connections prevent any risk of corrosion.
- New valve body internal design. Substantially higher flow coefficient and lower pressure drops. The degree of efficiency reached has also enabled the size and weight of the valve to be reduced. Adjustment linearity: the internal profiles of the valve greatly improve its characteristic curve, allowing extremely sensitive and precise adjustment along the entire length of the shutter stroke.
- Joint system for solvent welding (PVC-U and PVC-C only), for welding (PP-H and PVDF only), for threading and flanging
- Optimised fluid dynamic design: maximum output flow rate thanks to the optimised efficiency of the fluid dynamics that characterise the new internal geometry of the body
- Internal operating components in metal totally isolated from the conveyed fluid and external environment
- Modularity of the range: only 2 hand wheels and 4 diaphragms and bonnet sizes for 7 different valve sizes
- Non-salient hand wheel, equipped with a graduated optical indicator and protected by a transparent PVC cap with sealing O-ring.
- Bonnet fastening screws in STAINLESS steel protected by PE plugs. Absence of metal parts exposed to the external environment to prevent any risk of corrosion
- New flanged bodies: the new bodies, characterised by a monolithic flanged structure, are available in PVC-U, PVC-C, PP-H and PVDF. This design, free of joints between the body and flanges, greatly reduces mechanical stress and increases system performance
- CDSA seal system (Circular Diaphragm Sealing Angle) with a uniform distribution of the shutter pressure on the sealing membrane offers the following advantages:
  - Operating torque reduction
  - Reduced mechanical stress on all valve components (actuator, body and diaphragm)
  - Low risk of the accumulation of deposits, contamination or damage to the diaphragm due to crystallisation
  - Easy to clean valve interior