

DKUFV/CP NO – Pneumatically actuated 2-way diaphragm valve PN 10 DN 15:65

Pneumatically actuated diaphragm valve with BSP threaded female union ends. Normally Open function.

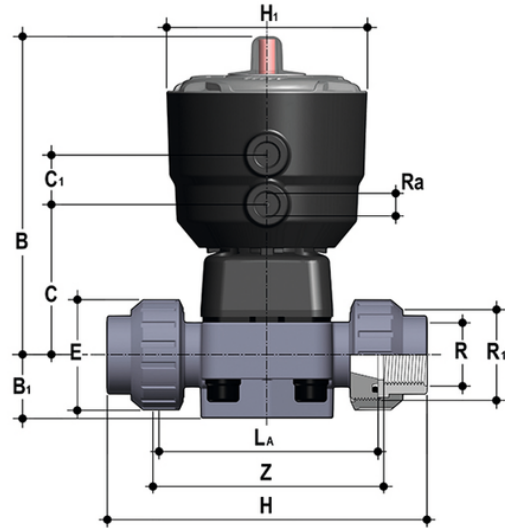

EPDM

Reference	R	DN	PN	B	B ₁	C	C ₁	E	H	H ₁	L[5:a]	R ₁	R[5:a]	Z	g
DKUFVNO012E	1/2"	15	10	148	25	66	24	41	131	97	90	1"	1/4"	97	735
DKUFVNO034E	3/4"	20	10	151	30	69	24	50	151	97	108	1 1/4"	1/4"	118	797
DKUFVNO100E	1"	25	10	159	33	78	24	58	165	97	116	1 1/2"	1/4"	127	1025
DKUFVNO114E	1 1/4"	32	10	163	30	82	24	72	188	97	134	2"	1/4"	145	1151
DKUFVNO112E	1 1/2"	40	10	207	35	112	24	79	208	126	154	2 1/2"	1/4"	165	2462
DKUFVNO200E	2"	50	10	245	46	142	24	98	246	157	184	2 3/4"	1/4"	195	4522

FKM

Reference	R	DN	PN	B	B ₁	C	C ₁	E	H	H ₁	L[5:a]	R ₁	R[5:a]	Z	g
DKUFVNO012F	1/2"	15	10	148	25	66	24	41	131	97	90	1"	1/4"	97	735
DKUFVNO034F	3/4"	20	10	151	30	69	24	50	151	97	108	1 1/4"	1/4"	118	797
DKUFVNO100F	1"	25	10	159	33	78	24	58	165	97	116	1 1/2"	1/4"	127	1025
DKUFVNO114F	1 1/4"	32	10	163	30	82	24	72	188	97	134	2"	1/4"	145	1151
DKUFVNO112F	1 1/2"	40	10	207	35	112	24	79	208	126	154	2 1/2"	1/4"	165	2462
DKUFVNO200F	2"	50	10	245	46	142	24	98	246	157	184	2 3/4"	1/4"	195	4522

PTFE



DKUFV/CP NO – Pneumatically actuated 2-way diaphragm valve

PN 10 DN 15:65

Reference	R	DN	PN	B	B ₁	C	C ₁	E	H	H ₁	L[5:a]	R ₁	R[5:a]	Z	g
DKUFVNO012P	1/2"	15	10	148	25	66	24	41	131	97	90	1"	1/4"	97	735
DKUFVNO034P	3/4"	20	10	151	30	69	24	50	151	97	108	1"1/4	1/4"	118	797
DKUFVNO100P	1"	25	10	159	33	78	24	58	165	97	116	1"1/2	1/4"	127	1025
DKUFVNO114P	1"1/4	32	10	163	30	82	24	72	188	97	134	2"	1/4"	145	1151
DKUFVNO112P	1"1/2	40	10	207	35	112	24	79	208	126	154	2"1/2	1/4"	165	2462
DKUFVNO200P	2"	50	10	245	46	142	24	98	246	157	184	2"3/4	1/4"	195	4522

DKUFV/CP NO – Pneumatically actuated 2-way diaphragm valve

PN 10 DN 15:65

The new compact and light piston actuator in PP-GR makes the DK/CP the ideal choice for applications requiring very frequent valve operation and a long valve lifetime.

- **High visibility graduated optical position indicator** protected by a transparent cap with a seal O-Ring
- **Compact and light piston in PP-GR**, ideal for heavy-duty applications in chemically aggressive environments with **a diaphragm perimeter containment system** that ensures the perfect compression of the rubber without any lateral expansion
- **Piston in high strength IXEF®**. The high quality finishing of the external surface guarantees perfect slidability over the seal and ensures a long working life without any actuator maintenance
- High strength **stainless steel stem** with double seal O-Ring. Floating **pin connection** between the actuator stem and diaphragm to prevent concentrated loads, improve the seal and extend its lifetime
- Actuator equipped with **6 independent cartridge springs** arranged radially to uniformly distribute the load on the piston
- **Dual function main gasket. Piston seal:** the gasket does not move but sits securely on the actuator cylinder instead of the piston. **External seal:** the gasket positioned above the threaded joint between the bonnet and cylinder ensures that the coupling is not stressed by the pressure inside the actuator
- Easy installation in confined spaces: **compressed air inlets with G 1/4" threaded adjustable connections** to enable alignment with the piping. PPGR connections prevent any risk of corrosion
- **New valve body internal design. Substantially higher flow coefficient** and lower pressure drops. The degree of efficiency reached has also enabled the **size and weight of the valve to be reduced. Adjustment linearity:** the internal profiles of the valve greatly improve its characteristic curve, allowing **extremely sensitive and precise adjustment** along the entire length of the shutter stroke
- Joint system for solvent welding (PVC-U and PVC-C only), for welding (PP-H and PVDF only), for threading and flanging
- **Optimised fluid dynamic design:** maximum output flow rate thanks to the optimised efficiency of the fluid dynamics that characterise the new internal geometry of the body
- **Internal operating components in metal totally isolated from the conveyed fluid** and external environment
- **Modularity of the range:** only 2 hand wheels and 4 diaphragms and bonnet sizes for 7 different valve sizes
- Non-salient hand wheel, equipped with a graduated optical indicator and protected by a transparent PVC cap with sealing O-ring
- Bonnet fastening screws in STAINLESS steel protected by PE plugs Absence of metal parts exposed to the external environment to prevent any risk of corrosion
- **New flanged bodies:** the new bodies, characterised by a monolithic flanged structure, are available in PVC-U, PVC-C, PP-H and PVDF. This design, free of joints between the body and flanges, greatly reduces mechanical stress and increases system performance
- **CDSA seal system** (Circular Diaphragm Sealing Angle) with a uniform distribution of the shutter pressure on the sealing membrane offers the following advantages:
 - Operating torque reduction
 - Reduced mechanical stress on all valve components (actuator, body and diaphragm)
 - Low risk of the accumulation of deposits, contamination or damage to the diaphragm due to crystallisation
 - Easy to clean valve interior