

VKDDV/CE 24 V AC/DC - Electrically actuated DUAL BLOCK® 2-way ball valve DN 10:50

DUAL BLOCK® ball valve with male ends for solvent welding, metric series with electric actuator 24 V AC/DC.

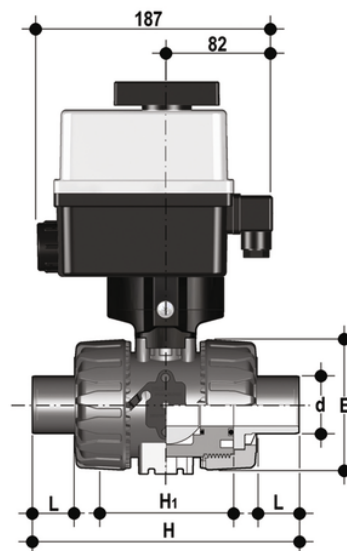

EPDM

Reference	d	DN	PN	E	H	H1	L	B	B ₁	g
VKDDVEL016E	16	10	16	54	149	65	14	205	29	1785
VKDDVEL020E	20	15	16	54	124	65	16	205	29	1775
VKDDVEL025E	25	20	16	65	144	70	19	216	34.5	1903
VKDDVEL032E	32	25	16	73	154	78	22	221	39	2011
VKDDVEL040E	40	32	16	86	174	88	26	238	46	2369
VKDDVEL050E	50	40	16	98	194	93	31	244	52	2601
VKDDVEL063E	63	50	*10	122	224	111	38	261	62	3218

FKM

Reference	d	DN	PN	E	H	H1	L	B	B ₁	g
VKDDVEL016F	16	10	16	54	149	65	14	205	29	1785
VKDDVEL020F	20	15	16	54	124	65	16	205	29	1775
VKDDVEL025F	25	20	16	65	144	70	19	216	34.5	1903
VKDDVEL032F	32	25	16	73	154	78	22	221	39	2011
VKDDVEL040F	40	32	16	86	174	88	26	238	46	2369
VKDDVEL050F	50	40	16	98	194	93	31	244	52	2601
VKDDVEL063F	63	50	*10	122	224	111	38	261	62	3218

VKDDV/CE 24 V AC/DC - Electrically actuated DUAL BLOCK® 2-way ball valve DN 10:50

In addition to the manually actuated version, VKD is also available in VKD/CE electrically actuated and VKD/CP pneumatically actuated configurations. Actuators are firmly connected to the valve by the special FIP Power Quick modules fully made of PP-GR technopolymer. VKD/CE and VKD/CP are constructed with actuators meeting current regulations and selected by FIP according to their quality and reliability requirements. The efficiency of these valves, tested according to the company's quality standards, is guaranteed by the expertise and know-how that FIP dedicates to manufacturing its products.

- Electric actuator constructed according to FIP specifications; with plastic shell and standard emergency override. Available with voltages from 12 to 240V
- Rack & pinion type pneumatic actuator constructed according to FIP specifications: fully protected against weather corrosion available in double-acting (DA) or simple-acting normally closed (NC) or normally open (NO) versions
- DUAL BLOCK® patented lock system that ensures union nut tightening hold even in severe conditions such as vibrations or heat dilation
- Double stem with double O-Rings for ball centring and operating torque reduction. The upper stem is also equipped with a co-moulded steel insert that guarantees high durability and perfect torque transmission between the actuator and ball
- Joint system for solvent welding (PVC-U and PVC-C only), for welding (PP-H and PVDF only), for threading and flanging
- Patented SEAT STOP® ball carrier system that lets you micro-adjust ball seats and minimise the axial force effect.
- Easy radial disassembly allowing quick replacement of O-rings and ball seats without any need for tools
- Radial dismounting valve body (True Union) made for PVC-U, PVC-C and PP-H injection moulding equipped with built-in bores for actuation. ISO 9393 compliant test requisites
- Option of disassembling downstream pipes with the valve in the closed position
- Floating full bore ball with high surface finish
- Integrated bracket for valve anchoring
- Possibility of installing a gear box or pneumatic and/or electric actuators by applying an ISO standard bore PP-GR flange
- Stainless steel co-moulded stem, with square section as per ISO 5211