

# TKDFV/CE 90-240 V AC - Electrically actuated DUAL BLOCK® 3-way ball valve DN 10:50

3 way DUAL BLOCK® ball valve with gas cylinder thread female ends with multi-volt electric actuator 90-240 V AC 50-60 Hz "T" ball, configuration 1

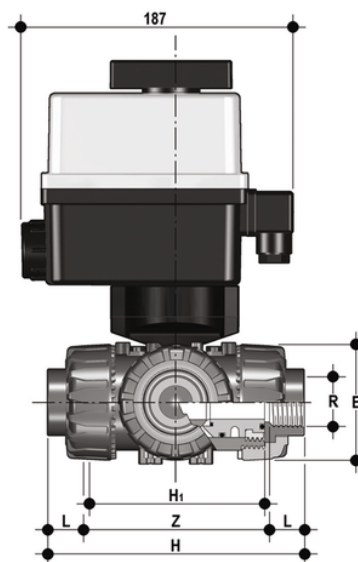

## EPDM

Reference	R	DN	PN	E	H	H1	L	Z	B	B <sub>1</sub>	g
TKDFVEM038E1	3/8"	10	16	54	118	80	11.4	95	205	29	1843
TKDFVEM012E1	1/2"	15	16	54	125	80	15	95	205	29	1843
TKDFVEM034E1	3/4"	20	16	65	146	100	16.3	114	216	34.5	2076
TKDFVEM100E1	1"	25	16	73	166	110	19.100000000000001	129	221	39	2299
TKDFVEM114E1	1" 1/4	32	16	86	195.5	131	21.4	151	238	46	2880
TKDFVEM112E1	1" 1/2	40	16	98	211	148	21.4	166	244	52	3242
TKDFVEM200E1	2"	50	*10	122	253.5	179	25.7	199	261	62	4362

## FKM

Reference	R	DN	PN	E	H	H1	L	Z	B	B <sub>1</sub>	g
TKDFVEM038F1	3/8"	10	16	54	118	80	11.4	95	205	29	1843
TKDFVEM012F1	1/2"	15	16	54	125	80	15	95	205	29	1843
TKDFVEM034F1	3/4"	20	16	65	146	100	16.3	114	216	34.5	2076
TKDFVEM100F1	1"	25	16	73	166	110	19.100000000000001	129	221	39	2299
TKDFVEM114F1	1" 1/4	32	16	86	195.5	131	21.4	151	238	46	2880
TKDFVEM112F1	1" 1/2	40	16	98	211	148	21.4	166	244	52	3242
TKDFVEM200F1	2"	50	*10	122	253.5	179	25.7	199	261	62	4362

# TKDFV/CE 90-240 V AC - Electrically actuated DUAL BLOCK® 3-way ball valve DN 10:50

In addition to the manually actuated version, TKD is also available in TKD/CE electrically actuated and TKD/CP pneumatically actuated configurations. Actuators are firmly connected to the valve by the special FIP PowerQuick modules fully made of PP-GR technopolymer. TKD/CE and TKD/CP are constructed with actuators meeting current regulations and selected by FIP according to their quality and reliability requirements. The efficiency of these valves, tested according to the company's quality standards, is guaranteed by the expertise and know-how that FIP dedicates to manufacturing its products.

- Electric actuator constructed according to FIP specifications; with plastic shell and standard emergency override. Available with voltages from 12 to 240V
- Rack & pinion type pneumatic actuator constructed according to FIP specifications: fully protected against weather corrosion available in double-acting (DA) or simple-acting normally closed (NC) or normally open (NO) versions. Three different positions according to 2 configurations are possible with T ball: 0°-90°-180° and 0°-90°-270°
- High surface finish stem with double O-Ring. The double connection key system guarantees solid and reliable actuator torque transmission to the ball
- Easy to install PowerQuick module for pneumatic or electric actuator fully made of highly robust technopolymer.
- DUAL BLOCK® patented lock system that ensures union nut tightening hold even in severe conditions such as vibrations or heat dilation
- Ball shutter high surface finish with floating type full passage with T or L port
- Joint system for solvent welding (PVC-U and PVC-C only), for welding (PP-H only), for threading
- Patented SEAT STOP® ball seat carrier system that lets you micro-adjust ball seats and minimise axial force effects
- Easy radial disassembly allowing quick replacement of O-rings and ball seats without any need for tools
- Radial dismounting valve body (True Union) made for PVC-U, PVC-C and PP-H injection moulding equipped with built-in bores for actuation. ISO 9393 compliant test requisites
- Option of disassembling downstream pipes with the valve in the closed position
- High surface finish stem with double O-Ring and double connection key to the ball, equipped with visual ball position indicator for correct handle installation
- Integrated bracket for valve anchoring
- Possibility of installing pneumatic and/or electric actuators thanks to the robust anchor tower for easy and quick automation using the PowerQuick module