

# VKDJV/CE 24 V AC/DC – Electrically actuated DUAL BLOCK® 2-way ball valve DN 10:50

2 way DUAL BLOCK® ball valve with female ends for solvent welding, JIS series with electric actuator 24 V AC/DC.

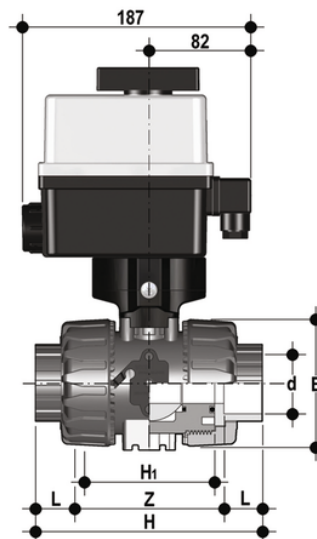

## EPDM

Reference	d	DN	PN	E	H	H1	L	Z	B	B <sub>1</sub>	g
VKDJV012E	1/2"	15	16	54	131	65	30	71	205	29	1775
VKDJV034E	3/4"	20	16	65	147	70	35	77	216	34.5	1903
VKDJV100E	1"	25	16	73	164	78	40	84	221	39	2011
VKDJV114E	1" 1/4	32	16	86	182	88	44	94	238	46	2369
VKDJV112E	1" 1/2	40	16	98	212	93	55	102	244	52	2601
VKDJV200E	2"	50	*10	122	248	111	63	122	261	62	3218

## FKM

Reference	d	DN	PN	E	H	H1	L	Z	B	B <sub>1</sub>	g
VKDJV012F	1/2"	15	16	54	131	65	30	71	205	29	1775
VKDJV034F	3/4"	20	16	65	147	70	35	77	216	34.5	1903
VKDJV100F	1"	25	16	73	164	78	40	84	221	39	2011
VKDJV114F	1" 1/4	32	16	86	182	88	44	94	238	46	2369
VKDJV112F	1" 1/2	40	16	98	212	93	55	102	244	52	2601
VKDJV200F	2"	50	*10	122	248	111	63	122	261	62	3218

# VKDJV/CE 24 V AC/DC - Electrically actuated DUAL BLOCK® 2-way ball valve DN 10:50

In addition to the manually actuated version, VKD is also available in VKD/CE electrically actuated and VKD/CP pneumatically actuated configurations. Actuators are firmly connected to the valve by the special FIP PowerQuick modules fully made of PP-GR technopolymer. VKD/CE and VKD/CP are constructed with actuators meeting current regulations and selected by FIP according to their quality and reliability requirements. The efficiency of these valves, tested according to the company's quality standards, is guaranteed by the expertise and know-how that FIP dedicates to manufacturing its products.

- Electric actuator constructed according to FIP specifications; with plastic shell and standard emergency override. Available with voltages from 12 to 240V
- Rack & pinion type pneumatic actuator constructed according to FIP specifications: fully protected against weather corrosion available in double-acting (DA) or simple-acting normally closed (NC) or normally open (NO) versions
- DUAL BLOCK® patented lock system that ensures union nut tightening hold even in severe conditions such as vibrations or heat dilation
- Double stem with double O-Rings for ball centring and operating torque reduction. The upper stem is also equipped with a co-moulded steel insert that guarantees high durability and perfect torque transmission between the actuator and ball
- Joint system for solvent welding (PVC-U and PVC-C only), for welding (PP-H and PVDF only), for threading and flanging
- Patented SEAT STOP® ball carrier system that lets you micro-adjust ball seats and minimise the axial force effect.
- Easy radial disassembly allowing quick replacement of O-rings and ball seats without any need for tools
- Radial dismounting valve body (True Union) made for PVC-U, PVC-C and PP-H injection moulding equipped with built-in bores for actuation. ISO 9393 compliant test requisites
- Option of disassembling downstream pipes with the valve in the closed position
- Floating full bore ball with high surface finish
- Integrated bracket for valve anchoring
- Possibility of installing a gear box or pneumatic and/or electric actuators by applying an ISO standard bore PP-GR flange
- Stainless steel co-moulded stem, with square section as per ISO 5211