

LKDIM/CE 24 V AC/DC - Electrically actuated DUAL BLOCK® 3-way ball valve DN 10:50

3 way DUAL BLOCK® ball valve with female ends for socket welding with electric actuator 24 V AC/DC "L" ball.

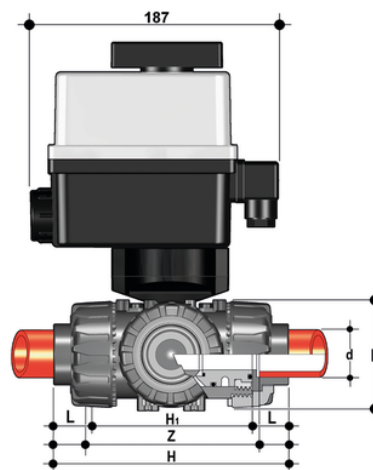

EPDM

Reference	d	DN	PN	E	H	H1	L	Z	B	B ₁	g
LKDIMEL016E1	16	10	10	54	118	80	14	89.5	205	29	1728
LKDIMEL020E1	20	15	10	54	118	80	15	88	205	29	1728
LKDIMEL025E1	25	20	10	65	145	100	16.5	112	216	34.5	1876
LKDIMEL032E1	32	25	10	73	160	110	19	122	221	39	2014
LKDIMEL040E1	40	32	10	86	188.5	131	23	142.5	238	46	2425
LKDIMEL050E1	50	40	10	98	219	148	23.5	172	244	52	2652
LKDIMEL063E1	63	50	10	122	266.5	179	27.7	211.15	261	62	3357

FKM

Reference	d	DN	PN	E	H	H1	L	Z	B	B ₁	g
LKDIMEL016F1	16	10	10	54	118	80	14	89.5	205	29	1728
LKDIMEL020F1	20	15	10	54	118	80	15	88	205	29	1728
LKDIMEL025F1	25	20	10	65	145	100	16.5	112	216	34.5	1876
LKDIMEL032F1	32	25	10	73	160	110	19	122	221	39	2014
LKDIMEL040F1	40	32	10	86	188.5	131	23	142.5	238	46	2425
LKDIMEL050F1	50	40	10	98	219	148	23.5	172	244	52	2652
LKDIMEL063F1	63	50	10	122	266.5	179	27.7	211.15	261	62	3357

LKDIM/CE 24 V AC/DC – Electrically actuated DUAL BLOCK® 3-way ball valve DN 10:50

In addition to the manually actuated version, TKD is also available in TKD/CE electrically actuated and TKD/CP pneumatically actuated configurations. Actuators are firmly connected to the valve by the special FIP PowerQuick modules fully made of PP-GR technopolymer. TKD/CE and TKD/CP are constructed with actuators meeting current regulations and selected by FIP according to their quality and reliability requirements. The efficiency of these valves, tested according to the company's quality standards, is guaranteed by the expertise and know-how that FIP dedicates to manufacturing its products.

- Electric actuator constructed according to FIP specifications; with plastic shell and standard emergency override. Available with voltages from 12 to 240V
- Rack & pinion type pneumatic actuator constructed according to FIP specifications: fully protected against weather corrosion available in double-acting (DA) or simple-acting normally closed (NC) or normally open (NO) versions. Three different positions according to 2 configurations are possible with T ball: 0°-90°-180° and 0°-90°-270°
- High surface finish stem with double O-Ring. The double connection key system guarantees solid and reliable actuator torque transmission to the ball
- Easy to install PowerQuick module for pneumatic or electric actuator fully made of highly robust technopolymer
- DUAL BLOCK® patented lock system that ensures union nut tightening hold even in severe conditions such as vibrations or heat dilation
- Ball shutter high surface finish with floating type full passage with T or L port
- Joint system for solvent welding (PVC-U and PVC-C only), for welding (PP-H only), for threading
- Patented SEAT STOP® ball seat carrier system that lets you micro-adjust ball seats and minimise axial force effects
- Easy radial disassembly allowing quick replacement of O-rings and ball seats without any need for tools
- Radial dismounting valve body (True Union) made for PVC-U, PVC-C and PP-H injection moulding equipped with built-in bores for actuation. ISO 9393 compliant test requisites
- Option of disassembling downstream pipes with the valve in the closed position
- High surface finish stem with double O-Ring and double connection key to the ball, equipped with visual ball position indicator for correct handle installation
- Integrated bracket for valve anchoring
- Possibility of installing pneumatic and/or electric actuators thanks to the robust anchor tower for easy and quick automation using the PowerQuick module