

VKDOM/CE 24 V AC/DC - Electrically actuated DUAL BLOCK® 2-way ball valve DN 10:50

Electrically actuated DUAL BLOCK® ball valve with DIN 2501 - EN 1092 fixed flanges, face to face according to EN 558-1 and electric actuator 24 V AC/DC.

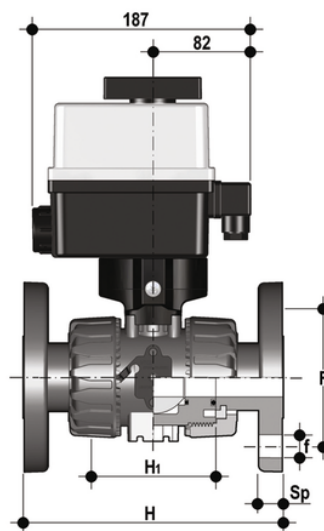

EPDM

Reference	d	DN	PN	H	H1	F	f	U	Sp	B	B ₁	g
VKDOMEL020E	20	15	10	130	65	65	14	4	11	205	29	1715
VKDOMEL025E	25	20	10	150	70	75	14	4	14	216	34.5	1791
VKDOMEL032E	32	25	10	160	78	85	14	4	14	221	39	1871
VKDOMEL040E	40	32	10	180	88	100	18	4	14	238	46	2156
VKDOMEL050E	50	40	10	200	93	110	18	4	16	244	52	2358
VKDOMEL063E	63	50	10	230	111	125	18	4	16	261	62	2807

FKM

Reference	d	DN	PN	H	H1	F	f	U	Sp	B	B ₁	g
VKDOMEL020F	20	15	10	130	65	65	14	4	11	205	29	1715
VKDOMEL025F	25	20	10	150	70	75	14	4	14	216	34.5	1791
VKDOMEL032F	32	25	10	160	78	85	14	4	14	221	39	1871
VKDOMEL040F	40	32	10	180	88	100	18	4	14	238	46	2156
VKDOMEL050F	50	40	10	200	93	110	18	4	16	244	52	2358
VKDOMEL063F	63	50	10	230	111	125	18	4	16	261	62	2807

VKDOM/CE 24 V AC/DC - Electrically actuated DUAL BLOCK® 2-way ball valve DN 10:50

In addition to the manually actuated version, VKD is also available in VKD/CE electrically actuated and VKD/CP pneumatically actuated configurations. Actuators are firmly connected to the valve by the special FIP PowerQuick modules fully made of PP-GR technopolymer. VKD/CE and VKD/CP are constructed with actuators meeting current regulations and selected by FIP according to their quality and reliability requirements. The efficiency of these valves, tested according to the company's quality standards, is guaranteed by the expertise and know-how that FIP dedicates to manufacturing its products.

- Electric actuator constructed according to FIP specifications; with plastic shell and standard emergency override. Available with voltages from 12 to 240V
- Rack & pinion type pneumatic actuator constructed according to FIP specifications: fully protected against weather corrosion available in double-acting (DA) or simple-acting normally closed (NC) or normally open (NO) versions
- DUAL BLOCK® patented lock system that ensures union nut tightening hold even in severe conditions such as vibrations or heat dilation
- Double stem with double O-Rings for ball centring and operating torque reduction. The upper stem is also equipped with a co-moulded steel insert that guarantees high durability and perfect torque transmission between the actuator and ball
- Joint system for solvent welding (PVC-U and PVC-C only), for welding (PP-H and PVDF only), for threading and flanging
- Patented SEAT STOP® ball carrier system that lets you micro-adjust ball seats and minimise the axial force effect.
- Easy radial disassembly allowing quick replacement of O-rings and ball seats without any need for tools
- Radial dismounting valve body (True Union) made for PVC-U, PVC-C and PP-H injection moulding equipped with built-in bores for actuation. ISO 9393 compliant test requisites
- Option of disassembling downstream pipes with the valve in the closed position
- Floating full bore ball with high surface finish
- Integrated bracket for valve anchoring
- Possibility of installing a gear box or pneumatic and/or electric actuators by applying an ISO standard bore PP-GR flange
- Stainless steel co-moulded stem, with square section as per ISO 5211