

VKDBM/CP DA - Pneumatically actuated DUAL BLOCK® 2-way ball valve DN 10:50

Pneumatically actuated DUAL BLOCK® ball valve with PP-H SDR 11 metric long spigot ends (CVDM) for welding, Double Acting.

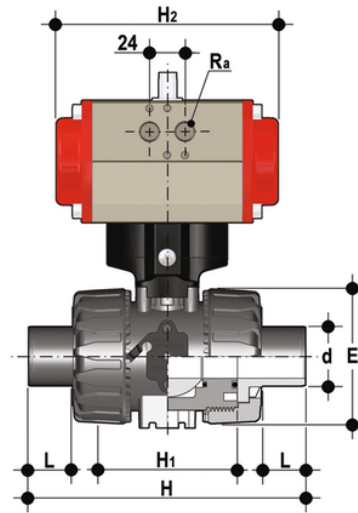
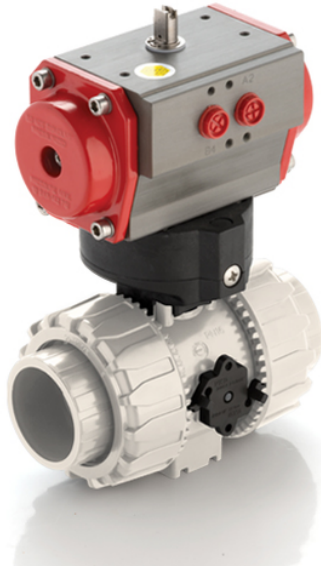

EPDM

Reference	d	DN	PN	E	H	H1	L	Z	H2	R _a	B	B ₁	E ₁
VKDBMDA020E	20	15	10	54	175	65	41	73	160	G1/8"	135	29	60.5
VKDBMDA025E	25	20	10	65	210	70	52	82	138	G1/8"	156.5	35	75
VKDBMDA032E	32	25	10	73	226	78	55	90	138	G1/8"	161	39	75
VKDBMDA040E	40	32	10	86	243	88	56	100	155.5	G1/4"	194	46	86
VKDBMDA050E	50	40	10	98	261	93	58	117	155.5	G1/4"	200	52	86
VKDBMDA063E	63	50	10	122	293	111	66	144	155.5	G1/4"	217	62	86

FKM

Reference	R	DN	PN	E	H	H1	L	Z	H2	R _a	B	B ₁	E ₁
VKDBMDA020F	20	15	10	54	175	65	41	73	160	G1/8"	135	29	60.5
VKDBMDA025F	25	20	10	65	210	70	52	82	138	G1/8"	156.5	35	75
VKDBMDA032F	32	25	10	73	226	78	55	90	138	G1/8"	161	39	75
VKDBMDA040F	40	32	10	86	243	88	56	100	155.5	G1/4"	194	46	86
VKDBMDA050F	50	40	10	98	261	93	58	117	155.5	G1/4"	200	52	86
VKDBMDA063F	63	50	10	122	293	111	66	144	155.5	G1/4"	217	62	86

VKDBM/CP DA – Pneumatically actuated DUAL BLOCK® 2-way ball valve DN 10:50

In addition to the manually actuated version, VKD is also available in VKD/CE electrically actuated and VKD/CP pneumatically actuated configurations. Actuators are firmly connected to the valve by the special FIP PowerQuick modules fully made of PP-GR technopolymer. VKD/CE and VKD/CP are constructed with actuators meeting current regulations and selected by FIP according to their quality and reliability requirements. The efficiency of these valves, tested according to the company's quality standards, is guaranteed by the expertise and know-how that FIP dedicates to manufacturing its products.

- Electric actuator constructed according to FIP specifications; with plastic shell and standard emergency override. Available with voltages from 12 to 240V
- Rack & pinion type pneumatic actuator constructed according to FIP specifications: fully protected against weather corrosion available in double-acting (DA) or simple-acting normally closed (NC) or normally open (NO) versions
- DUAL BLOCK® patented lock system that ensures union nut tightening hold even in severe conditions such as vibrations or heat dilation
- Double stem with double O-Rings for ball centring and operating torque reduction. The upper stem is also equipped with a co-moulded steel insert that guarantees high durability and perfect torque transmission between the actuator and ball
- Joint system for solvent welding (PVC-U and PVC-C only), for welding (PP-H and PVDF only), for threading and flanging
- Patented SEAT STOP® ball carrier system that lets you micro-adjust ball seats and minimise the axial force effect
- Easy radial disassembly allowing quick replacement of O-rings and ball seats without any need for tools
- Radial dismounting valve body (True Union) made for PVC-U, PVC-C and PP-H injection moulding equipped with built-in bores for actuation. ISO 9393 compliant test requisites
- Option of disassembling downstream pipes with the valve in the closed position
- Floating full bore ball with high surface finish
- Integrated bracket for valve anchoring
- Possibility of installing a gear box or pneumatic and/or electric actuators by applying an ISO standard bore PP-GR flange
- Stainless steel co-moulded stem, with square section as per ISO 5211