

# VKDIM/CE 24 V AC/DC - Electrically actuated DUAL BLOCK® 2-way ball valve DN 10:50

Electrically actuated DUAL BLOCK® ball valve with metric plain socket ends for socket welding and electric actuator 24 V AC/DC.

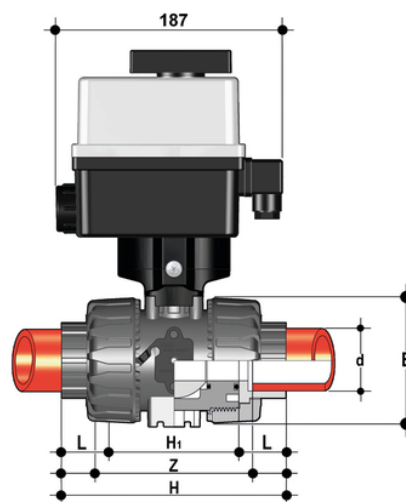

## EPDM

Reference	d	DN	PN	E	H	H1	L	Z	B	B <sub>1</sub>	g
VKDIMELO16E	16	10	10	54	102	65	14	74,5	205	29	1720
VKDIMELO20E	20	15	10	54	102	65	15	73	205	29	1715
VKDIMELO25E	25	20	10	65	114	70	17	82	216	34.5	1791
VKDIMELO32E	32	25	10	73	126	78	19	90	221	39	1871
VKDIMELO40E	40	32	10	86	141	88	23	100	238	46	2156
VKDIMELO50E	50	40	10	98	164	93	24	117	244	52	2358
VKDIMELO63E	63	50	10	122	199	111	28	144	261	62	2807

## FKM

Reference	d	DN	PN	E	H	H1	L	Z	B	B <sub>1</sub>	g
VKDIMELO16F	16	10	10	54	102	65	14	74,5	205	29	1720
VKDIMELO20F	20	15	10	54	102	65	15	73	205	29	1715
VKDIMELO25F	25	20	10	65	114	70	17	82	216	34.5	1791
VKDIMELO32F	32	25	10	73	126	78	19	90	221	39	1871
VKDIMELO40F	40	32	10	86	141	88	23	100	238	46	2156
VKDIMELO50F	50	40	10	98	164	93	24	117	244	52	2358
VKDIMELO63F	63	50	10	122	199	111	28	144	261	62	2807

# VKDIM/CE 24 V AC/DC - Electrically actuated DUAL BLOCK® 2-way ball valve DN 10:50

In addition to the manually actuated version, VKD is also available in VKD/CE electrically actuated and VKD/CP pneumatically actuated configurations. Actuators are firmly connected to the valve by the special FIP PowerQuick modules fully made of PP-GR technopolymer. VKD/CE and VKD/CP are constructed with actuators meeting current regulations and selected by FIP according to their quality and reliability requirements. The efficiency of these valves, tested according to the company's quality standards, is guaranteed by the expertise and know-how that FIP dedicates to manufacturing its products.

- Electric actuator constructed according to FIP specifications; with plastic shell and standard emergency override. Available with voltages from 12 to 240V
- Rack & pinion type pneumatic actuator constructed according to FIP specifications: fully protected against weather corrosion available in double-acting (DA) or simple-acting normally closed (NC) or normally open (NO) versions
- DUAL BLOCK® patented lock system that ensures union nut tightening hold even in severe conditions such as vibrations or heat dilation
- Double stem with double O-Rings for ball centring and operating torque reduction. The upper stem is also equipped with a co-moulded steel insert that guarantees high durability and perfect torque transmission between the actuator and ball
- Joint system for solvent welding (PVC-U and PVC-C only), for welding (PP-H and PVDF only), for threading and flanging
- Patented SEAT STOP® ball carrier system that lets you micro-adjust ball seats and minimise the axial force effect.
- Easy radial disassembly allowing quick replacement of O-rings and ball seats without any need for tools
- Radial dismounting valve body (True Union) made for PVC-U, PVC-C and PP-H injection moulding equipped with built-in bores for actuation. ISO 9393 compliant test requisites
- Option of disassembling downstream pipes with the valve in the closed position
- Floating full bore ball with high surface finish
- Integrated bracket for valve anchoring
- Possibility of installing a gear box or pneumatic and/or electric actuators by applying an ISO standard bore PP-GR flange
- Stainless steel co-moulded stem, with square section as per ISO 5211