

# VKRBF/CE 24 V AC/DC 4-20 mA - Electrically actuated DUAL BLOCK® regulating ball valve DN 10:50

Electrically actuated DUAL BLOCK® regulating ball valve with PVDF SDR 21 metric long spigot ends (CVDF) for butt welding and modulating electric actuator 24 V AC/DC.

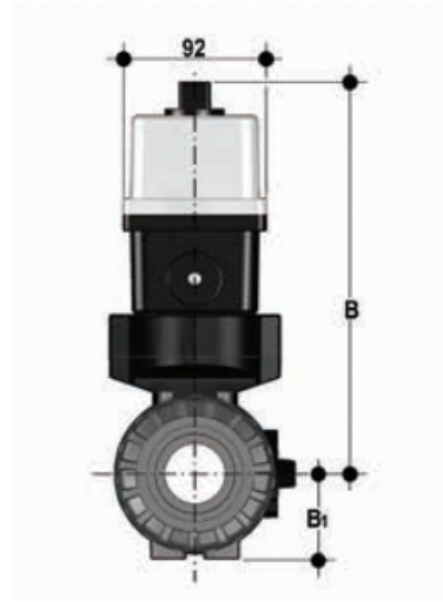
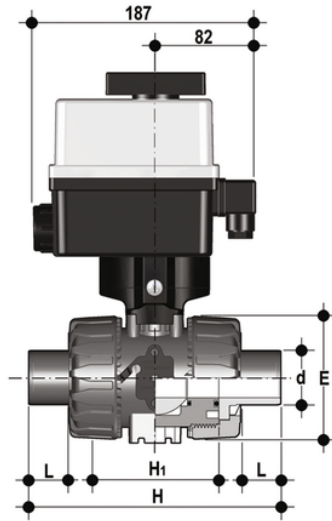

Reference	d	DN	B	B <sub>1</sub>	PN	E	H	H <sub>1</sub>	L	Z	g
VKRBFEL020FOE	20	15	205	29	16	54	171	65	41	89	1825
VKRBFEL025FOE	25	20	216	34.5	16	65	204	70	52	100	1963
VKRBFEL032FOE	32	25	221	39	16	73	220	78	55	110	2123
VKRBFEL040FOE	40	32	238	46	16	86	238	88	56	126	2491
VKRBFEL050FOE	50	40	244	52	16	98	254	93	58	138	2826
VKRBFEL063FOE	63	50	261	62	*10	122	286	111	66	154	3611

# VKRBF/CE 24 V AC/DC 4-20 mA - Electrically actuated DUAL BLOCK<sup>®</sup> regulating ball valve DN 10:50

In addition to the manually actuated version, VKR is also available in electrically actuated VKR/CE configuration. Actuators are firmly connected to the valve by the special FIP PowerQuick modules fully made of PP-GR technopolymer. VKR/CE are constructed with actuators meeting current regulations and selected by FIP according to their quality and reliability requirements. The efficiency of these valves, tested according to the company's quality standards, is guaranteed by the expertise and know-how that FIP dedicates to manufacturing its products.

- Electric modulating actuator constructed according to FIP specifications; with plastic shell and standard emergency override. Available with voltages from 12 to 240V with 4-20mA and 0-10 V input
- High surface finish stem with double O-Ring. The double connection key system guarantees solid and reliable actuator torque transmission to the ball
- Easy to install PowerQuick module for pneumatic or electric actuator fully made of highly robust technopolymer
- The patented ball design provides linear flow regulation throughout its range of operation even when the valve is open just a few degrees and guarantees minimum pressure drops
- Patented DUAL BLOCK<sup>®</sup> system: prevents union nuts from loosening even under extreme operating conditions: e.g. vibration or thermal expansion
- Joint system for solvent welding (PVC-U only), for welding (PP-H and PVDF only), for threading and flanging
- Patented SEAT STOP<sup>®</sup> ball carrier system that lets you micro-adjust ball seats and minimise the axial force effect.
- Easy radial disassembly allowing quick replacement of O-rings and ball seats without any need for tools
- Radial dismounting valve body (True Union) made for PVC-U, PVC-C and PVDF-H injection moulding equipped with built-in bores for actuation. ISO 9393 compliant test requisites
- Option of disassembling downstream pipes with the valve in the closed position
- High surface finish stem with double O-Ring and double groove ball connection
- Integrated bracket for valve anchoring
- Ball seat carrier can be adjusted using the Easytorque adjustment kit
- Actuation option: version with electric modulating actuator with 4-20 mA / 0-10 V inlet and 4-20 mA / 0-10 V outlet to monitor the position
- Valve suitable for carrying fluids that are clean and free of suspended particles