

# TKDIM/CP DA - Pneumatically actuated DUAL BLOCK® 3-way ball valve DN 10:50

3 way DUAL BLOCK® ball valve with female ends for socket welding with electric actuator, Double-Acting function. "T" ball, configuration 1.

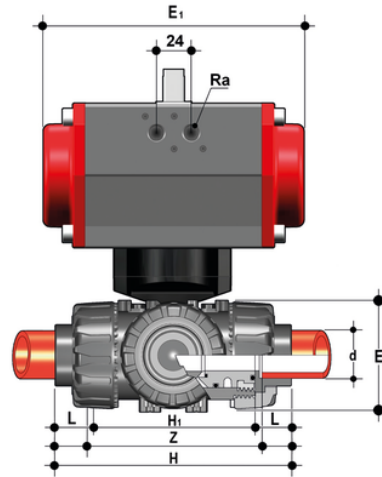

## EPDM

Reference	d	DN	PN	E	H	H1	L	Z	R <sub>a</sub>	B	B <sub>1</sub>	E <sub>1</sub>	E <sub>2</sub>	g
TKDIMDA016E1	16	10	10	54	118	80	14	90	G1/8"	145	29	138	75	1442
TKDIMDA020E1	20	15	10	54	117	80	14.5	88	G1/8"	145	29	138	86	1972
TKDIMDA025E1	25	20	10	65	144	100	16	112	G1/4"	156.5	34.5	155.5	86	2236
TKDIMDA032E1	32	25	10	73	158	110	18	122	G1/4"	161	39	155.5	86	2532
TKDIMDA040E1	40	32	10	86	184	131	20.5	143	G1/4"	194	46	155.5	86	3025
TKDIMDA050E1	50	40	10	98	219	148	23.5	172	G1/4"	200	52	155.5	86	3410
TKDIMDA063E1	63	50	10	122	267	179	27.5	212	G1/4"	200	62	155.5	86	5944

## FKM

Reference	d	DN	PN	E	H	H1	L	Z	R <sub>a</sub>	B	B <sub>1</sub>	E <sub>1</sub>	E <sub>2</sub>	g
TKDIMDA016F1	16	10	10	54	118	80	14	90	G1/8"	145	29	138	75	1442
TKDIMDA020F1	20	15	10	54	117	80	14.5	88	G1/8"	145	29	138	86	1972
TKDIMDA025F1	25	20	10	65	144	100	16	112	G1/4"	156.5	34.5	155.5	86	2236
TKDIMDA032F1	32	25	10	73	158	110	18	122	G1/4"	161	39	155.5	86	2532
TKDIMDA040F1	40	32	10	86	184	131	20.5	143	G1/4"	194	46	155.5	86	3025
TKDIMDA050F1	50	40	10	98	219	148	23.5	172	G1/4"	200	52	155.5	86	3410
TKDIMDA063F1	63	50	10	122	267	179	27.5	212	G1/4"	200	62	155.5	86	5944

# TKDIM/CP DA – Pneumatically actuated DUAL BLOCK® 3-way ball valve DN 10:50

In addition to the manually actuated version, TKD is also available in TKD/CE electrically actuated and TKD/CP pneumatically actuated configurations. Actuators are firmly connected to the valve by the special FIP PowerQuick modules fully made of PP-GR technopolymer. TKD/CE and TKD/CP are constructed with actuators meeting current regulations and selected by FIP according to their quality and reliability requirements. The efficiency of these valves, tested according to the company's quality standards, is guaranteed by the expertise and know-how that FIP dedicates to manufacturing its products.

- Electric actuator constructed according to FIP specifications; with plastic shell and standard emergency override. Available with voltages from 12 to 240V
- Rack & pinion type pneumatic actuator constructed according to FIP specifications: fully protected against weather corrosion available in double-acting (DA) or simple-acting normally closed (NC) or normally open (NO) versions. Three different positions according to 2 configurations are possible with T ball: 0°-90°-180° and 0°-90°-270°
- High surface finish stem with double O-Ring. The double connection key system guarantees solid and reliable actuator torque transmission to the ball
- Easy to install PowerQuick module for pneumatic or electric actuator fully made of highly robust technopolymer
- DUAL BLOCK® patented lock system that ensures union nut tightening hold even in severe conditions such as vibrations or heat dilation
- Ball shutter high surface finish with floating type full passage with T or L port
- Joint system for solvent welding (PVC-U and PVC-C only), for welding (PP-H only), for threading
- Patented SEAT STOP® ball seat carrier system that lets you micro-adjust ball seats and minimise axial force effects
- Easy radial disassembly allowing quick replacement of O-rings and ball seats without any need for tools
- Radial dismounting valve body (True Union) made for PVC-U, PVC-C and PP-H injection moulding equipped with built-in bores for actuation. ISO 9393 compliant test requisites
- Option of disassembling downstream pipes with the valve in the closed position
- High surface finish stem with double O-Ring and double connection key to the ball, equipped with visual ball position indicator for correct handle installation
- Integrated bracket for valve anchoring
- Possibility of installing pneumatic and/or electric actuators thanks to the robust anchor tower for easy and quick automation using the PowerQuick module