

RVOV-RVOT D 20 ÷ 63 - Sediment strainer DN 10:100

RVOV PVC-U rigid - RVOT PVC-U transparent.
Sediment strainer with fixed flanges, drilled PN10/16.

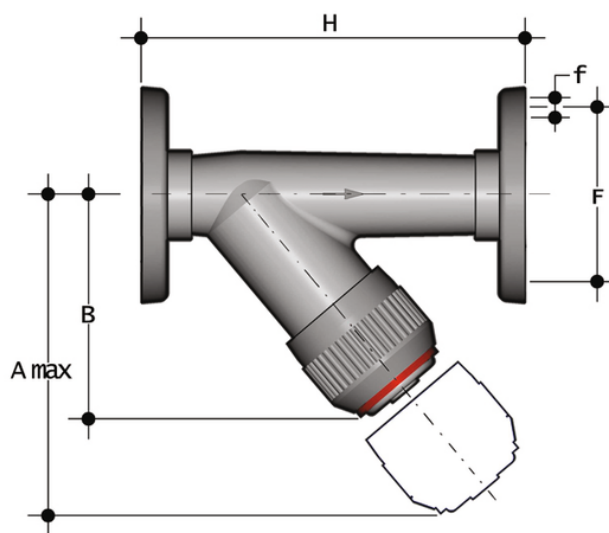

EPDM

Reference	d	DN	PN RVOV	PN RVOT	A max	B	F	f	H	Fig.	g
RVOV020E	20	15	16	10	125	72	65	14	130	A	260
RVOT050E	50	40	16	10	210	120	110	18	200	A	1170
RVOT040E	40	32	16	10	190	111	100	18	180	A	850
RVOT032E	32	25	16	10	165	95	85	14	160	A	560
RVOT025E	25	20	16	10	145	84	75	14	150	A	395
RVOT020E	20	15	16	10	125	72	65	14	130	A	260
RVOV063E	63	50	16	10	240	139	125	18	230	A	1760
RVOV050E	50	40	16	10	210	120	110	18	200	A	1170
RVOV040E	40	32	16	10	190	111	100	18	180	A	850
RVOV032E	32	25	16	10	165	95	85	14	160	A	560
RVOV025E	25	20	16	10	145	84	75	14	150	A	395
RVOT063E	63	50	16	10	240	139	125	18	230	A	1760



RVOV-RVOT D 20 ÷ 63 - Sediment strainer DN 10:100

- Connection system for solvent weld, threaded and flanged joints
- **Strainer** mounted on an easily removed **support** that facilitates the cleaning or replacement
- **Valve material compatibility** (PVC-U) with water conveyance, drinking water and other food substances according to **current regulations**
- Can be maintained with the valve body installed