

# RVDV-RVDT – Sediment strainer DN 10:100

RVDV PVC-U rigid - RVDT PVC-U transparent.  
Sediment strainer with male ends for solvent welding.

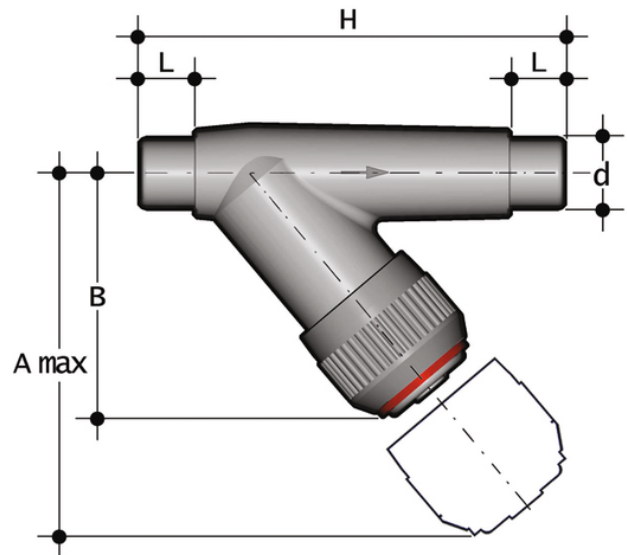

## EPDM

Reference	d	DN	PN RVDV	PN RVDT	A max	B	H	L	Fig.	g
RVDV016E	16	10	16	10	125	72	114	14	A	110
RVDT050E	50	40	16	10	210	120	194	31	A	600
RVDT040E	40	32	16	10	190	111	174	26	A	400
RVDT032E	32	25	16	10	165	95	154	22	A	285
RVDT025E	25	20	16	10	145	84	144	19	A	190
RVDT020E	20	15	16	10	125	72	124	16	A	120
RVDT016E	16	10	16	10	125	72	114	14	A	110
RVDV063E	63	50	16	10	240	139	224	38	A	945
RVDV050E	50	40	16	10	210	120	194	31	A	600
RVDV040E	40	32	16	10	190	111	174	26	A	400
RVDV032E	32	25	16	10	165	95	154	22	A	285
RVDV025E	25	20	16	10	145	84	144	19	A	190
RVDV020E	20	15	16	10	125	72	124	16	A	120
RVDT063E	63	50	16	10	240	139	224	38	A	945



# RVDV-RVDT – Sediment strainer DN 10:100

- Connection system for solvent weld, threaded and flanged joints
- **Strainer** mounted on an easily removed **support** that facilitates the cleaning or replacement
- **Valve material compatibility** (PVC-U) with water conveyance, drinking water and other food substances according to **current regulations**
- Can be maintained with the valve body installed