

RVAT - Sediment strainer DN 10:100

PVC-U transparent.

Sediment strainer with female ends for solvent welding, series ASTM.

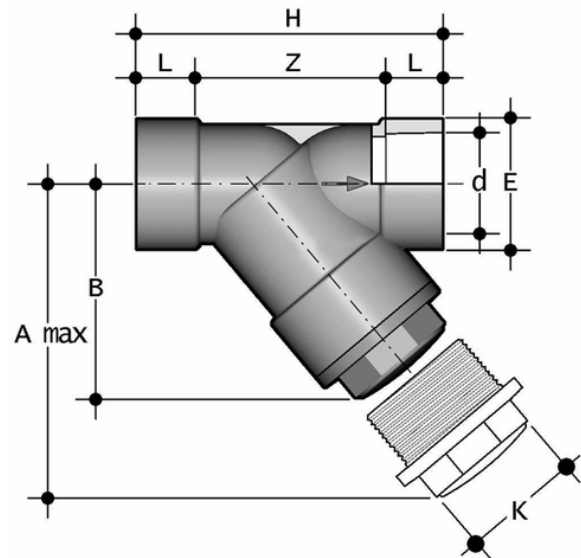

Reference	d	DN	PN	A max	B	E	H	K	L	Z	Fig.	g
RVAT300E	3"	80	4	325	192	116	262	105	47,6	166,8	B	2975
RVAT400E	4"	100	4	385	231	138	325	-	57,2	210,6	C	4610



RVAT - Sediment strainer DN 10:100

- Connection system for solvent weld, threaded and flanged joints
- **Strainer** mounted on an easily removed **support** that facilitates the cleaning or replacement
- **Valve material compatibility** (PVC-U) with water conveyance, drinking water and other food substances according to **current regulations**
- Can be maintained with the valve body installed