

VROV D 75 ÷ 110 – Check valve DN 10:100

Check valve with PVC-U backing ring, drilled PN10/16.

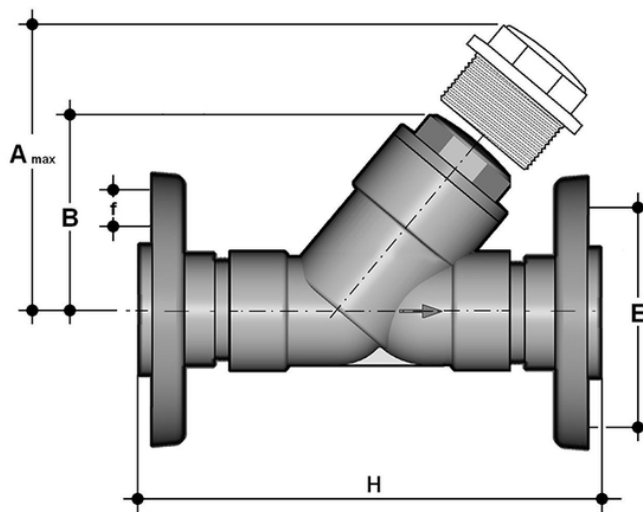

EPDM

Reference	d	DN	PN	A max	B	F	f	H	Fig.	g
VROV075E	75	65	10	300	179	145	17	356	B	4600
VROV090E	90	80	6	325	192	160	17	404	B	6300
VROV110E	110	100	6	385	231	180	17	475	C	9200

FKM

Reference	d	DN	PN	A max	B	F	f	H	Fig.	g
VROV075F	75	65	10	300	179	145	17	356	B	4600
VROV090F	90	80	6	325	192	160	17	404	B	6300
VROV110F	110	100	6	385	231	180	17	475	C	9200



VROV D 75 ÷ 110 – Check valve DN 10:100

- Connection system for solvent weld, threaded and flanged joints
- **No metal parts in contact with the fluid**
- **Piston with counterweight** able to work with high intensity fluid
- Limited pressure drop. Only minimum back pressure is required for the hermetic seal
- **Valve material compatibility** (PVC-U) with water conveyance, drinking water and other food substances according to **current regulations**
- Can be maintained with the valve body installed