

VROV D 20 ÷ 63 - Check valve DN 10:100

Check valve with fixed flanges, drilled PN10/16.

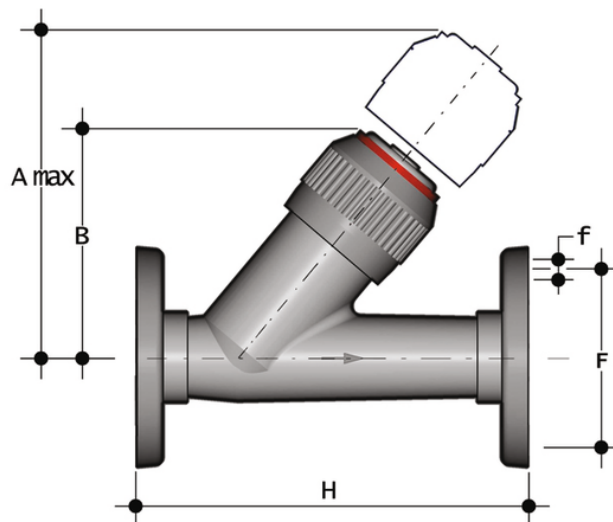

EPDM

| Reference | d | DN | PN | A max | B | F | f | H | Fig. | g |
|-----------|----|----|----|-------|-----|-----|----|-----|------|------|
| VROV020E | 20 | 15 | 16 | 125 | 72 | 65 | 14 | 130 | A | 280 |
| VROV025E | 25 | 20 | 16 | 145 | 84 | 75 | 14 | 150 | A | 430 |
| VROV032E | 32 | 25 | 16 | 165 | 95 | 85 | 14 | 160 | A | 640 |
| VROV040E | 40 | 32 | 16 | 190 | 111 | 100 | 18 | 180 | A | 1035 |
| VROV050E | 50 | 40 | 16 | 210 | 120 | 110 | 18 | 200 | A | 1405 |
| VROV063E | 63 | 50 | 16 | 240 | 139 | 125 | 18 | 230 | A | 2235 |

FKM

| Reference | d | DN | PN | A max | B | F | f | H | Fig. | g |
|-----------|----|----|----|-------|-----|-----|----|-----|------|------|
| VROV020F | 20 | 15 | 16 | 125 | 72 | 65 | 14 | 130 | A | 280 |
| VROV025F | 25 | 20 | 16 | 145 | 84 | 75 | 14 | 150 | A | 430 |
| VROV032F | 32 | 25 | 16 | 165 | 95 | 85 | 14 | 160 | A | 640 |
| VROV040F | 40 | 32 | 16 | 190 | 111 | 100 | 18 | 180 | A | 1035 |
| VROV050F | 50 | 40 | 16 | 210 | 120 | 110 | 18 | 200 | A | 1405 |
| VROV063F | 63 | 50 | 16 | 240 | 139 | 125 | 18 | 230 | A | 2235 |

VROV D 20 ÷ 63 – Check valve DN 10:100

- Connection system for solvent weld, threaded and flanged joints
- **No metal parts in contact with the fluid**
- **Piston with counterweight** able to work with high intensity fluid
- Limited pressure drop. Only minimum back pressure is required for the hermetic seal
- **Valve material compatibility** (PVC-U) with water conveyance, drinking water and other food substances according to **current regulations**
- Can be maintained with the valve body installed