

VRDV – Check valve DN 10:100

Check valve with male ends for solvent welding, metric series.

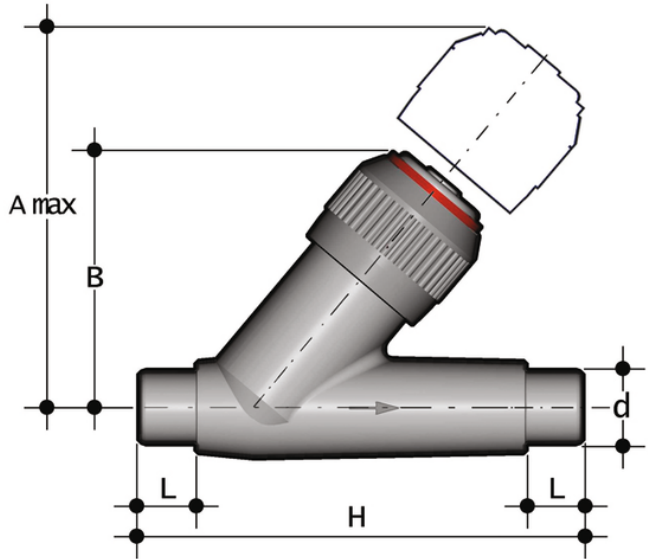

Reference	d	DN	PN	A max	B	H	L	Fig.	g
VRDV016E	16	10	16	125	72	114	14	A	125
VRDV020E	20	15	16	125	72	124	16	A	135
VRDV025E	25	20	16	145	84	144	19	A	225
VRDV032E	32	25	16	165	95	154	22	A	360
VRDV040E	40	32	16	190	111	174	26	A	590
VRDV050E	50	40	16	210	120	194	31	A	835
VRDV063E	63	50	16	240	139	224	38	A	1420



VRDV – Check valve DN 10:100

- Connection system for solvent weld, threaded and flanged joints
- **No metal parts in contact with the fluid**
- **Piston with counterweight** able to work with high intensity fluid
- Limited pressure drop. Only minimum back pressure is required for the hermetic seal
- **Valve material compatibility** (PVC-U) with water conveyance, drinking water and other food substances according to **current regulations**
- Can be maintained with the valve body installed