

VMOAV – Diaphragm valve DN 80:100

Diaphragm valve with flanged monolithic body, drilled ANSI B16.5 cl. 150 #FF.

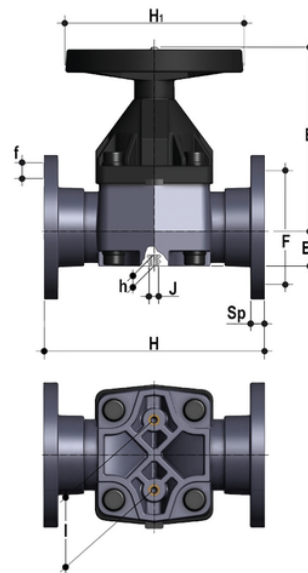

EPDM

Reference	d	DN	PN	B	B ₁	F	f	H	H ₁	I	J	Sp	U	g
VMOAV300E	3"	80	*10	225	64	152,4	19,1	263	200	100	M12	21,5	4	8500
VMOAV400E	4"	100	*10	295	72	190,5	19,1	328	250	120	M12	22,5	8	12400

FKM

Reference	d	DN	PN	B	B ₁	F	f	H	H ₁	I	J	Sp	U	g
VMOAV300F	3"	80	*10	225	64	152,4	19,1	263	200	100	M12	21,5	4	8500
VMOAV400F	4"	100	*10	295	72	190,5	19,1	328	250	120	M12	22,5	8	12400

PTFE

Reference	d	DN	PN	B	B ₁	F	f	H	H ₁	I	J	Sp	U	g
VMOAV300P	3"	80	*10	225	64	152,4	19,1	263	200	100	M12	21,5	4	8500
VMOAV400P	4"	100	*10	295	72	190,5	19,1	328	250	120	M12	22,5	8	12400

VMOAV – Diaphragm valve DN 80:100

- **Handwheel** in (PA-GR) with high mechanical strength and ergonomic **grip for optimum manageability**
- **Metal optical position indicator** supplied as standard
- **Full protection bonnet in PP-GR** Internal circular and symmetrical diaphragm sealing area
- Diaphragm available in EPDM, FPM, PTFE (NBR on request) and easy to replace
- **Threaded metal inserts** for anchoring the valve
- **New valve body internal design:** substantially higher flow coefficient resulting in lower pressure drops. Optimised adjustment curve for effective and precise flow rate regulation

- Connection system for solvent welding and for flanged joints
- **Optimised fluid dynamic design:** maximum output flow rate thanks to the optimised efficiency of the fluid dynamics that characterise the new internal geometry of the body
- Handwheel that stays at the same height during rotation, with internal bearing to minimise friction and operating torque
- Standard optical indicator
- **Internal operating components in metal** totally isolated from the conveyed fluid
- Bonnet fastening screws in STAINLESS steel protected against the external environment by PE plugs
- **New flanged bodies:** the new bodies, characterised by a monolithic flanged structure, are available in PVC-U, PVC-C, PP-H and PVDF. This design, free from body and flange joints, greatly reduces mechanical stress and increases system performance.