

# VRUFV - Check valve DN 10:100

Check valve with BSP threaded female union ends.

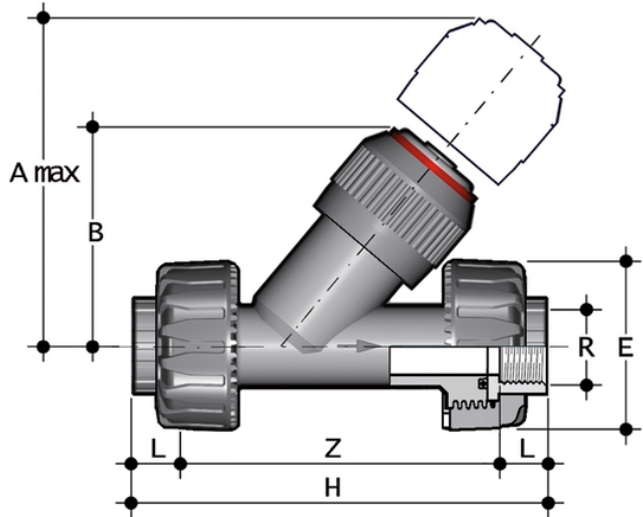

Reference	R	DN	PN	A max	B	E	H	L	Z	Fig.	g
VRUFV038E	3/8"	10	16	125	72	55	135	11,4	112,2	A	221
VRUFV012E	1/2"	15	16	125	72	55	143	15	113	A	230
VRUFV034E	3/4"	20	16	145	84	66	160	16,3	127,4	A	390
VRUFV100E	1"	25	16	165	95	75	183	19,1	144,8	A	602
VRUFV114E	1" 1/4	32	16	190	111	87	214	21,4	171,2	A	932
VRUFV112E	1" 1/2	40	16	210	120	100	235	21,4	192,2	A	1341
VRUFV200E	2"	50	16	240	139	120	285	25,7	233,6	A	2348



## VRUFV – Check valve DN 10:100

- Connection system for solvent weld, threaded and flanged joints
- **No metal parts in contact with the fluid**
- **Piston with counterweight** able to work with high intensity fluid
- Limited pressure drop. Only minimum back pressure is required for the hermetic seal
- **Valve material compatibility** (PVC-U) with water conveyance, drinking water and other food substances according to **current regulations**
- Can be maintained with the valve body installed