

VRIV - Check valve DN 10:100

Check valve with female ends for solvent welding, metric series.

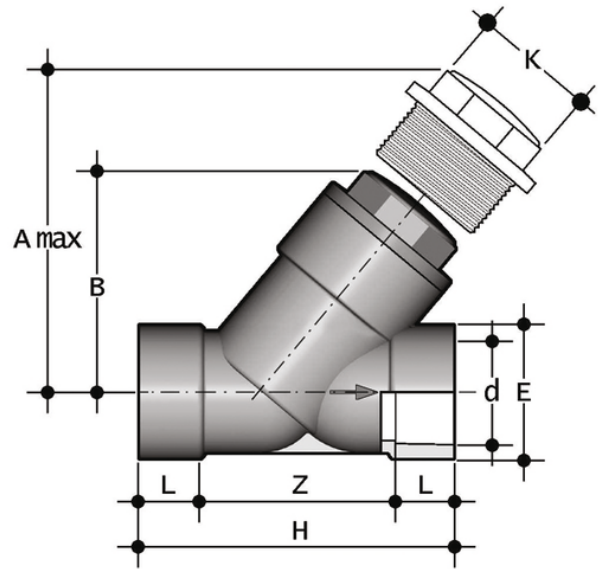

Reference	d	DN	PN	A max	B	E	H	K	L	Z	Fig.	g
VRIV075E	75	65	10	300	179	104	243	96	44	155	B	3485
VRIV090E	90	80	6	325	192	116	262	105	51	160	B	4530
VRIV110E	110	100	6	385	231	138	325	-	61	203	C	7170



VRIV – Check valve DN 10:100

- Connection system for solvent weld, threaded and flanged joints
- **No metal parts in contact with the fluid**
- **Piston with counterweight** able to work with high intensity fluid
- Limited pressure drop. Only minimum back pressure is required for the hermetic seal
- **Valve material compatibility** (PVC-U) with water conveyance, drinking water and other food substances according to **current regulations**
- Can be maintained with the valve body installed