

VVUFV - Angle seat valve DN 10:50

Angle seat valve with BSP threaded female union ends.

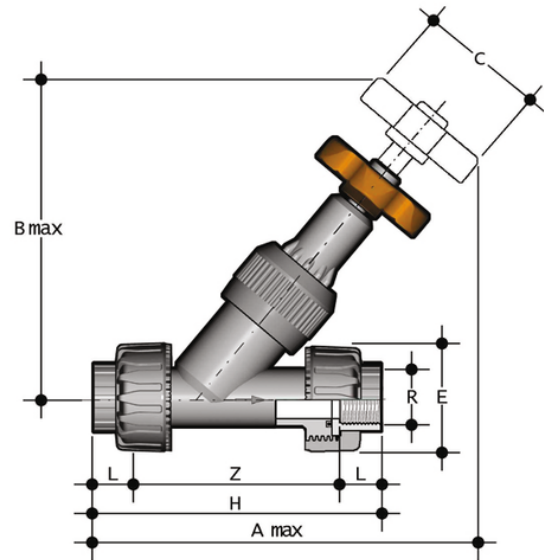

Reference	R	DN	PN	A max	B max	C	E	H	L	Z	g
VVUFV012E	1/2"	15	16	173	124	60	55	143	15	113	251
VVUFV034E	3/4"	20	16	197	146	60	66	160	16,3	127,4	413
VVUFV100E	1"	25	16	223	173	70	75	183	19,1	144,8	621
VVUFV114E	1 1/4"	32	10	258	195	85	87	214	21,4	171,2	903
VVUFV112E	1 1/2"	40	10	295	222	105	100	235	21,4	192,2	1320
VVUFV200E	2"	50	10	359	269	130	120	285	25,7	233,6	2238
VVUFV038E	3/8"	10	16	170	124	60	55	135	11,4	112,2	238



VVUFV - Angle seat valve DN 10:50

- Connection system for solvent weld, threaded and flanged joints
- Can be installed in any position
- **No metal parts in contact with the fluid**
- **Valve material compatibility** (PVC-U) with water, drinking water and other food substance conveyance according to **current regulations**
- Can be maintained with the valve body installed