

# VVUIV - Angle seat valve DN 10:50

Angle seat valve with female union ends for solvent welding, metric series.

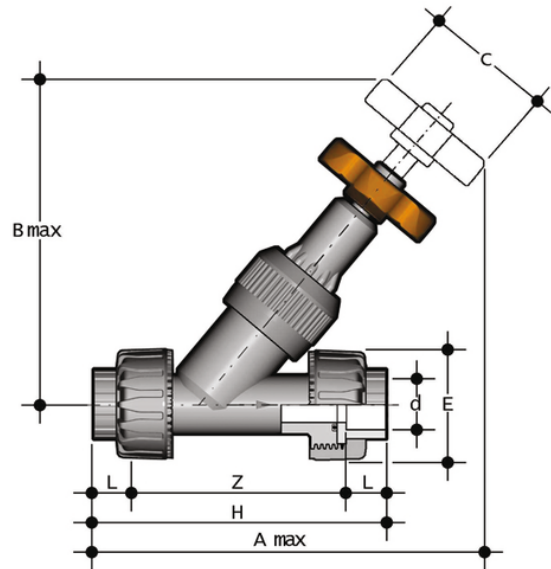

Reference	d	DN	PN	A max	B max	C	E	H	L	Z	g
VVUIV016E	16	10	16	170	124	60	55	135	14	107	238
VVUIV020E	20	15	16	173	124	60	55	135	16	103	251
VVUIV025E	25	20	16	197	146	60	66	158	19	120	413
VVUIV032E	32	25	16	223	173	70	75	176	22	132	621
VVUIV040E	40	32	16	258	195	85	87	207	26	155	903
VVUIV050E	50	40	16	295	222	105	100	243	31	181	1320
VVUIV063E	63	50	16	359	269	130	120	298	38	222	2238



## VVUIV - Angle seat valve DN 10:50

- Connection system for solvent weld, threaded and flanged joints
- Can be installed in any position
- **No metal parts in contact with the fluid**
- **Valve material compatibility** (PVC-U) with water, drinking water and other food substance conveyance according to **current regulations**
- Can be maintained with the valve body installed