

RVUOAC – Sediment strainer DN 15:50

Sediment strainer with fixed flanges, drilled ANSI B16.5 cl.150 #FF.

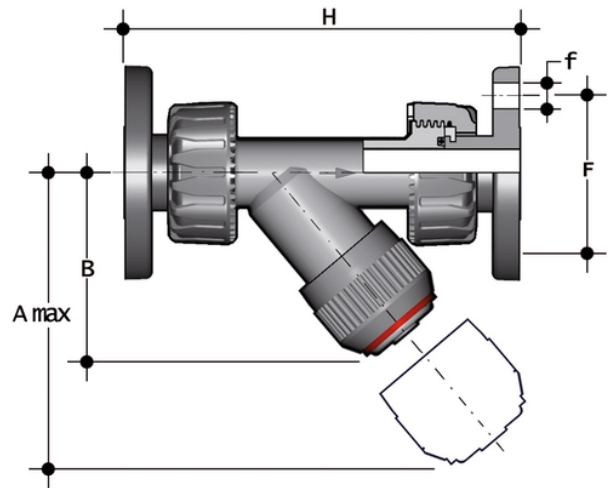

EPDM

Reference	Size	DN	PN	A max	B	F	f	H	g
RVUOAC012E	1/2"	15	16	125	72	60,3	15,9	175	360
RVUOAC034E	3/4"	20	16	145	84	69,9	15,9	214	495
RVUOAC100E	1"	25	16	165	95	79,4	15,9	237	660
RVUOAC114E	1 1/4"	32	16	190	111	88,9	15,9	253	1000
RVUOAC112E	1 1/2"	40	16	210	120	98,4	15,9	289	1320
RVUOAC200E	2"	50	16	240	139	120,7	19,1	333	1910

FKM

Reference	Size	DN	PN	A max	B	F	f	H	g
RVUOAC012F	1/2"	15	16	125	72	60,3	15,9	175	360
RVUOAC034F	3/4"	20	16	145	84	69,9	15,9	214	495
RVUOAC100F	1"	25	16	165	95	79,4	15,9	237	660
RVUOAC114F	1 1/4"	32	16	190	111	88,9	15,9	253	1000
RVUOAC112F	1 1/2"	40	16	210	120	98,4	15,9	289	1320
RVUOAC200F	2"	50	16	240	139	120,7	19,1	333	1910



RVUOAC – Sediment strainer DN 15:50

- Connection system for solvent weld, threaded and flanged joints
- **Strainer** mounted on an easily removed **support** that facilitates the cleaning or replacement
- **Valve material compatibility** (PVC-C) with water conveyance, drinking water and other food substances according to **current regulations**
- Can be maintained with the valve body installed