

# DKLDC - DIALOCK® 2-way diaphragm valve DN 15:65

DIALOCK® diaphragm valve with stroke limiter and male ends for solvent welding, metric series.

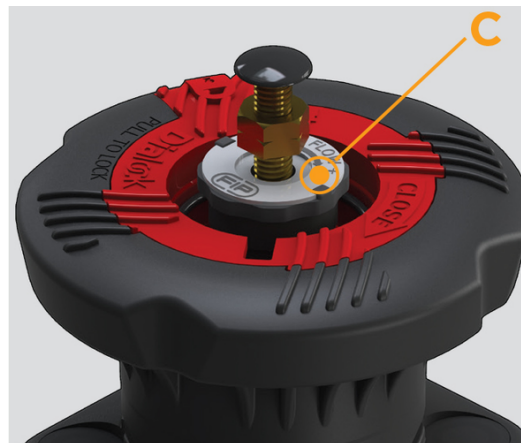
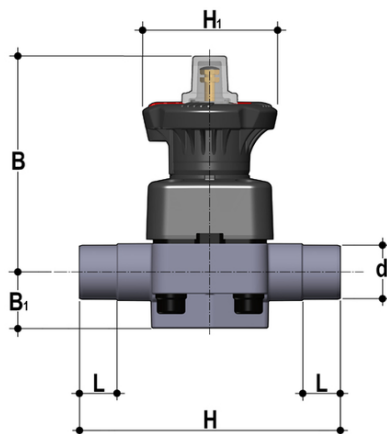

## EPDM

Reference	d	DN	PN	B	B <sub>1</sub>	H	H <sub>1</sub>	L	g
DKLDC020E	20	15	10	115	25	124	80	16	496
DKLDC025E	25	20	10	118	30	144	80	19	521
DKLDC032E	32	25	10	127	33	154	80	22	726
DKLDC040E	40	32	10	132	30	174	80	26	773
DKLDC050E	50	40	10	175	35	194	120	31	1634
DKLDC063E	63	50	10	200	46	224	120	38	2370
DKLDC075E	75	65	10	200	46	284	120	44	2490

## FKM

Reference	d	DN	PN	B	B <sub>1</sub>	H	H <sub>1</sub>	L	g
DKLDC020F	20	15	10	115	25	124	80	16	496
DKLDC025F	25	20	10	118	30	144	80	19	521
DKLDC032F	32	25	10	127	33	154	80	22	726
DKLDC040F	40	32	10	132	30	174	80	26	773
DKLDC050F	50	40	10	175	35	194	120	31	1634
DKLDC063F	63	50	10	200	46	224	120	38	2370
DKLDC075F	75	65	10	200	46	284	120	44	2490

## PTFE



# DKLDC - DIALOCK® 2-way diaphragm valve DN 15:65

Reference	d	DN	PN	B	B <sub>1</sub>	H	H <sub>1</sub>	L	g
DKLDC020P	20	15	10	115	25	124	80	16	496
DKLDC025P	25	20	10	118	30	144	80	19	521
DKLDC032P	32	25	10	127	33	154	80	22	726
DKLDC040P	40	32	10	132	30	174	80	26	773
DKLDC050P	50	40	10	175	35	194	120	31	1634
DKLDC063P	63	50	10	200	46	224	120	38	2370
DKLDC075P	75	65	10	200	46	284	120	44	2490

# DKLDC – DIALOCK® 2-way diaphragm valve DN 15:65

- **High visibility graduated optical position indicator** protected by a transparent cap with seal O-Ring
- **Customisation plate:** the customisation lets you identify the valve on the system according to specific needs
- **DIALOCK® SYSTEM:** innovative handwheel with a patented immediate and ergonomic operating locking device that allows it **to be adjusted and locked in over 300 positions**
- **Handwheel and bonnet in** high mechanical strength and chemically resistant **PP-GR**, providing full protection by isolating all internal metal parts from contact with external agents
- **Floating pin connection** between the control screw and diaphragm to prevent concentrated loads, improve the seal and extend its lifetime
- **New design of valve body interior: substantially increased flow coefficient** and reduced pressure drop. The degree of efficiency reached has also **enabled the size and weight of the valve to be reduced**
- **Adjustment linearity:** the internal profiles of the valve also greatly improve its characteristic curve, resulting in **extremely sensitive and precise adjustment** along the entire stroke of the shutter
- **Valve anchoring** bracket **integrated in the body**, with threaded metal inserts allowing **simple panel or wall mounting** using the PMDK mounting plate (supplied as an accessory)
  
- Connection system for solvent weld, threaded and flanged joints
- **Optimised fluid dynamic design:** maximum output flow rate thanks to the optimised efficiency of the fluid dynamics that characterise the new internal geometry of the body
- **Internal components in metal, totally isolated from the fluid** and external environment
- **Modularity of the range:** only 2 handwheel and 4 diaphragm and bonnet sizes for 7 different valve sizes
- Non-rising handwheel that stays at the same height during rotation, equipped with a graduated optical indicator protected by a transparent PVC cap with seal O-Ring
- Bonnet fastening screws in stainless steel protected against the external environment by PE plugs. Absence of metal parts exposed to the external environment to prevent any risk of corrosion.
- **CDSA** (Circular Diaphragm Sealing Angle) system that, thanks to the uniform distribution of shutter pressure on the diaphragm seal, offers the following advantages:
  - reduction in the tightening torque of the screws fixing the actuator to the valve body
  - reduced mechanical stress on all valve components (actuator, body and diaphragm)
  - easy to clean valve interior
  - low risk of the accumulation of deposits, contamination or damage to the diaphragm due to crystallisation
  - operating torque reduction