

# RVUOC - Sediment strainer DN 15:50

Sediment strainer with fixed flanges, drilled EN/ISO/DIN PN10/16.

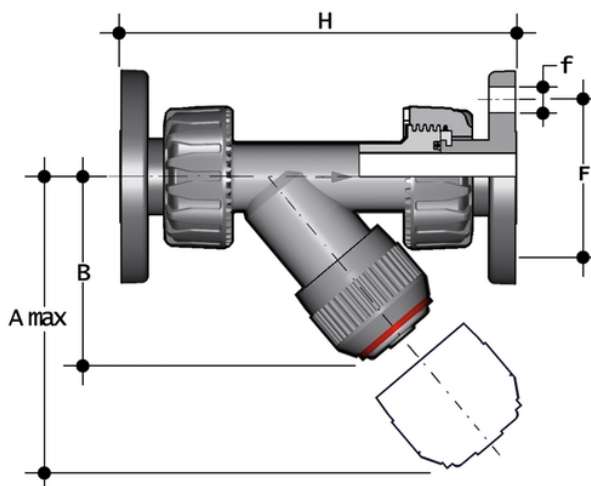

## EPDM

| Reference | d  | DN | PN | A max | B   | F   | f  | H   | g    |
|-----------|----|----|----|-------|-----|-----|----|-----|------|
| RVUOC020E | 20 | 15 | 16 | 125   | 72  | 65  | 14 | 163 | 360  |
| RVUOC025E | 25 | 20 | 16 | 145   | 84  | 75  | 14 | 193 | 495  |
| RVUOC032E | 32 | 25 | 16 | 165   | 95  | 85  | 14 | 211 | 660  |
| RVUOC040E | 40 | 32 | 16 | 190   | 111 | 100 | 18 | 244 | 1000 |
| RVUOC050E | 50 | 40 | 16 | 210   | 120 | 110 | 18 | 277 | 1320 |
| RVUOC063E | 63 | 50 | 16 | 240   | 139 | 125 | 18 | 331 | 1910 |

## FKM

| Reference | d  | DN | PN | A max | B   | F   | f  | H   | g    |
|-----------|----|----|----|-------|-----|-----|----|-----|------|
| RVUOC020F | 20 | 15 | 16 | 125   | 72  | 65  | 14 | 163 | 360  |
| RVUOC025F | 25 | 20 | 16 | 145   | 84  | 75  | 14 | 193 | 495  |
| RVUOC032F | 32 | 25 | 16 | 165   | 95  | 85  | 14 | 211 | 660  |
| RVUOC040F | 40 | 32 | 16 | 190   | 111 | 100 | 18 | 244 | 1000 |
| RVUOC050F | 50 | 40 | 16 | 210   | 120 | 110 | 18 | 277 | 1320 |
| RVUOC063F | 63 | 50 | 16 | 240   | 139 | 125 | 18 | 331 | 1910 |



# RVUOC – Sediment strainer DN 15:50

- Connection system for solvent weld, threaded and flanged joints
- **Strainer** mounted on an easily removed **support** that facilitates the cleaning or replacement
- **Valve material compatibility** (PVC-C) with water conveyance, drinking water and other food substances according to **current regulations**
- Can be maintained with the valve body installed