

# RVUNC - Sediment strainer DN 15:50

Sediment strainer with NPT threaded female union ends.

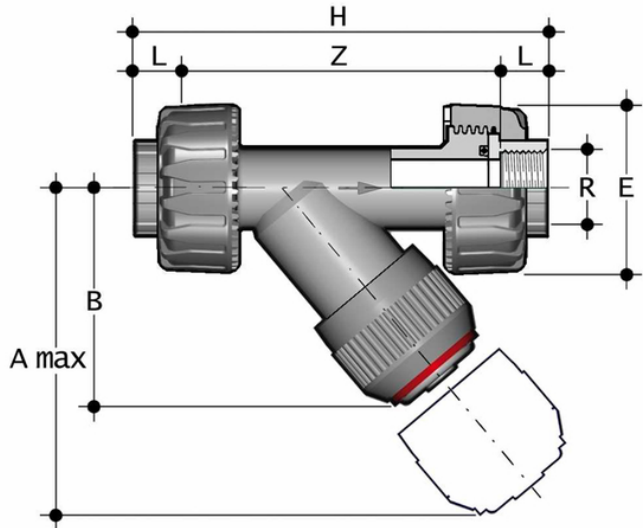

## EPDM

Reference	R	DN	PN	A max	B	E	H	L	Z	g
RVUNC012E	1/2"	15	16	125	72	55	143	17,8	107,4	231
RVUNC034E	3/4"	20	16	145	84	66	159	18	123	392
RVUNC100E	1"	25	16	165	95	75	183	22,6	137,8	576
RVUNC114E	1" 1/4	32	16	190	111	87	214	25,1	163,8	812
RVUNC112E	1" 1/2	40	16	210	120	100	235	24,7	185,6	1211
RVUNC200E	2"	50	16	240	139	120	285	29,6	275,8	2051

## FKM

Reference	R	DN	PN	A max	B	E	H	L	Z	g
RVUNC012F	1/2"	15	16	125	72	55	143	17,8	107,4	231
RVUNC034F	3/4"	20	16	145	84	66	159	18	123	392
RVUNC100F	1"	25	16	165	95	75	183	22,6	137,8	576
RVUNC114F	1" 1/4	32	16	190	111	87	214	25,1	163,8	812
RVUNC112F	1" 1/2	40	16	210	120	100	235	24,7	185,6	1211
RVUNC200F	2"	50	16	240	139	120	285	29,6	225,8	2051



# RVUNC – Sediment strainer DN 15:50

- Connection system for solvent weld, threaded and flanged joints
- **Strainer** mounted on an easily removed **support** that facilitates the cleaning or replacement
- **Valve material compatibility** (PVC-C) with water conveyance, drinking water and other food substances according to **current regulations**
- Can be maintained with the valve body installed