

RVOAM – Sediment strainer DN 15:100

Sediment strainer with steel core backing ring , PP/FRP coated, drilled ANSI B16.5 cl.150 #FF.

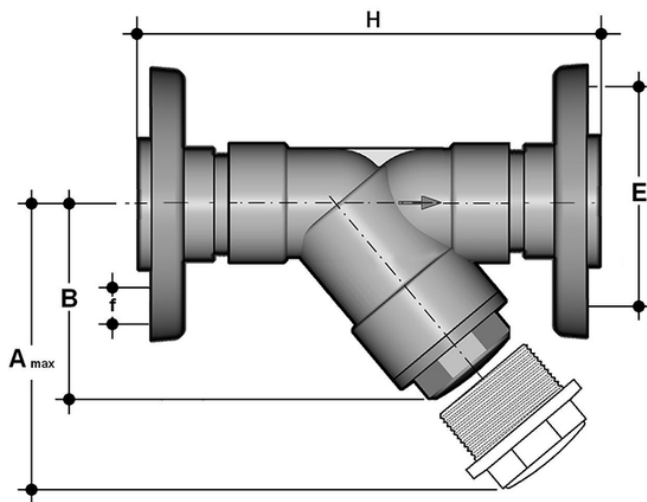

EPDM

Reference	d - Size	DN	PN	A max	B	F	f	H	g
RVOAM212E	75 - 2"1/2	65	6	300	179	139,7	18	356	4725
RVOAM300E	90 - 3"	80	4	325	192	152,4	18	404	5175
RVOAM400E	110 - 4"	100	4	385	231	190,5	18	475	7405

FKM

Reference	d - Size	DN	PN	A max	B	F	f	H	g
RVOAM212F	75 - 2"1/2	65	6	300	179	139,7	18	356	4725
RVOAM300F	90 - 3"	80	4	325	192	152,4	18	404	5175
RVOAM400F	110 - 4"	100	4	385	231	190,5	18	475	7405



RVOAM – Sediment strainer DN 15:100

- Connection system for weld, threaded and flanged joints
- **Strainer** assembled on an **easily removed support** that facilitates cleaning or replacement
- **Valve material compatibility** (PP-H) with water conveyance, drinking water and other food substances according to **current regulations**
- Can be maintained with the valve body installed