

RVUIC - Sediment strainer DN 15:50

Sediment strainer with female union ends for solvent welding, metric series.

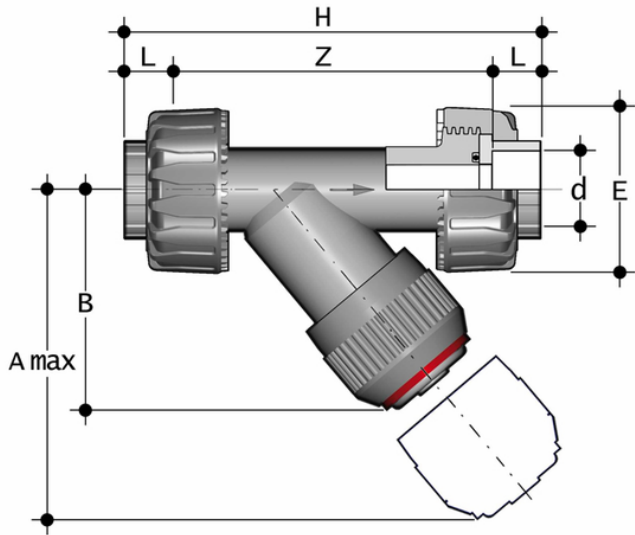

EPDM

Reference	d	DN	PN	A max	B	E	H	L	Z	g
RVUIC020E	20	15	16	125	72	55	135	16	103	231
RVUIC025E	25	20	16	145	84	66	158	19	120	392
RVUIC032E	32	25	16	165	95	75	176	22	132	576
RVUIC040E	40	32	16	190	111	87	207	26	155	802
RVUIC050E	50	40	16	210	120	100	243	31	181	1199
RVUIC063E	63	50	16	240	139	120	298	38	222	2018

FKM

Reference	d	DN	PN	A max	B	E	H	L	Z	g
RVUIC020F	20	15	16	125	72	55	135	16	103	231
RVUIC025F	25	20	16	145	84	66	158	19	120	392
RVUIC032F	32	25	16	165	95	75	176	22	132	576
RVUIC040F	40	32	16	190	111	87	207	26	155	802
RVUIC050F	50	40	16	210	120	100	243	31	181	1199
RVUIC063F	63	50	16	240	139	120	298	38	222	2018



RVUIC – Sediment strainer DN 15:50

- Connection system for solvent weld, threaded and flanged joints
- **Strainer** mounted on an easily removed **support** that facilitates the cleaning or replacement
- **Valve material compatibility** (PVC-C) with water conveyance, drinking water and other food substances according to **current regulations**
- Can be maintained with the valve body installed