

RVOM - Sediment strainer DN 15:100

Sediment strainer with steel core backing ring , PP/FRP coated, drilled EN/ISO/DIN PN10/16.

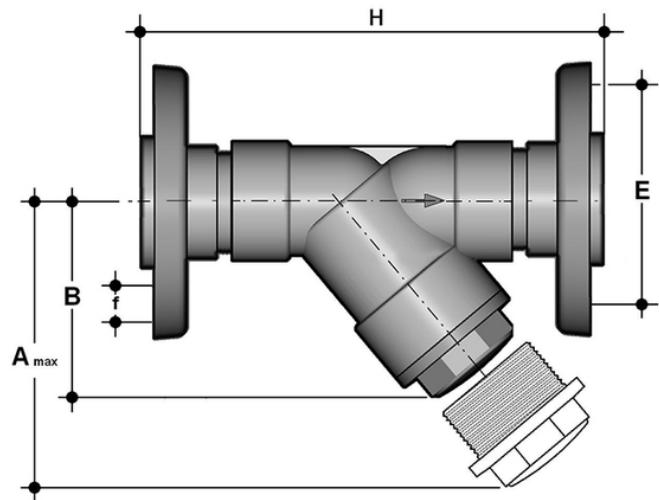

EPDM

| Reference | d | DN | PN | A max | B | F | f | H | g |
|-----------|-----|-----|----|-------|-----|-----|----|-----|------|
| RVOM075E | 75 | 65 | 6 | 300 | 176 | 145 | 18 | 356 | 5120 |
| RVOM090E | 90 | 80 | 4 | 325 | 192 | 160 | 18 | 404 | 6020 |
| RVOM110E | 110 | 100 | 4 | 385 | 231 | 180 | 18 | 475 | 7965 |

FKM

| Reference | d | DN | PN | A max | B | F | f | H | g |
|-----------|-----|-----|----|-------|-----|-----|----|-----|------|
| RVOM075F | 75 | 65 | 6 | 300 | 176 | 145 | 18 | 356 | 5120 |
| RVOM090F | 90 | 80 | 4 | 325 | 192 | 160 | 18 | 404 | 6020 |
| RVOM110F | 110 | 100 | 4 | 385 | 231 | 180 | 18 | 475 | 7925 |



RVOM - Sediment strainer DN 15:100

- Connection system for weld, threaded and flanged joints
- **Strainer** assembled on an **easily removed support** that facilitates cleaning or replacement
- **Valve material compatibility** (PP-H) with water conveyance, drinking water and other food substances according to **current regulations**
- Can be maintained with the valve body installed