

CMUIC - Compact diaphragm valve DN 12:15

Compact diaphragm valve with female union ends for solvent welding.

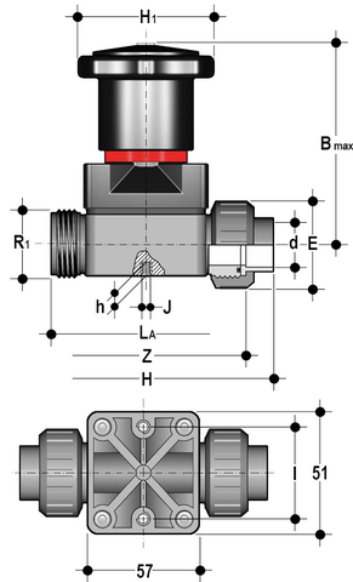

EPDM

Reference	d	DN	PN	B max	E	H	H ₁	h	I	J	LA	R ₁	Z	g
CMUIC020E	20	15	6	86	41	129,5	58,5	8	35	M5	90	1"	97,5	310

FKM

Reference	d	DN	PN	B max	E	H	H ₁	h	I	J	LA	R ₁	Z	g
CMUIC020F	20	15	6	86	41	129,5	58,5	8	35	M5	90	1"	97,5	310

PTFE

Reference	d	DN	PN	B max	E	H	H ₁	h	I	J	LA	R ₁	Z	g
CMUIC020P	20	15	6	86	41	129,5	58,5	8	35	M5	90	1"	97,5	310

CMUIC – Compact diaphragm valve DN 12:15

- **Handwheel in PA-GR, completely sealed**, high mechanical strength with ergonomic grip for optimum manageability
- **Integrated adjustable torque limiter** designed to prevent excessive compression of the diaphragm and always guarantee a minimum fluid flow
- **Optical position indicator** supplied as standard
- **Bonnet in PA-GR with STAINLESS steel nuts** fully protected by plastic plugs to eliminate zones where impurities may accumulate. Internal circular and symmetrical diaphragm sealing area
- **STAINLESS steel bolts**, can also be inserted from above
- **Threaded metal inserts** for anchoring the valve

- Connection system for solvent weld and threaded joints
- Extremely compact construction
- **Internal operating components in metal totally isolated from the conveyed fluid**
- Valve stem in STAINLESS steel
- **Compressor with floating diaphragm support**
- Easy to replace diaphragm seal
- Corrosion-proof internal components
- **CDSA** (Circular Diaphragm Sealing Angle) system offering the following advantages:
 - uniform distribution of shutter pressure on the diaphragm seal
 - reduction in the tightening torque of the crews fixing the actuator to the valve body
 - reduced mechanical stress on all valve components (actuator, body and diaphragm)
 - easy to clean valve interior
 - low risk of the accumulation of eposits, contamination or damage to the diaphragm due to crystallisation
 - operating torque reduction