

RVUOM – Sediment strainer DN 15:100

Sediment strainer with female union ends and fixed flanges, drilled EN/ISO/DIN PN10/16.

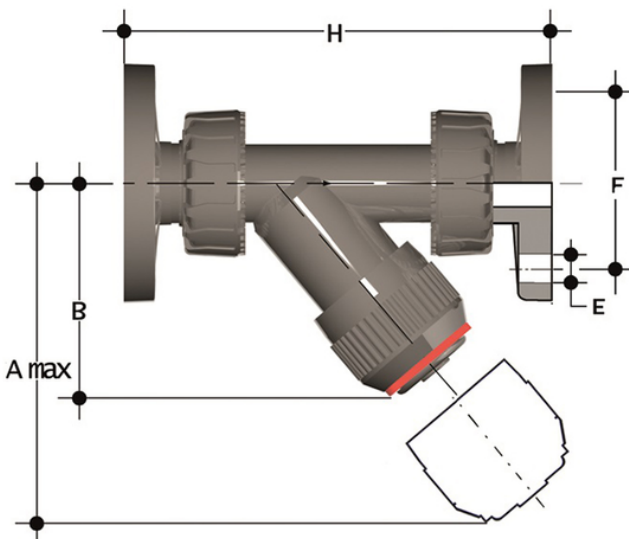

EPDM

Reference	d	DN	PN	A max	B	F	f	H	g
RVUOM020E	20	15	10	125	72	65	14	163	248
RVUOM025E	25	20	10	145	84	75	14	193	295
RVUOM032E	32	25	10	165	95	85	14	211	397
RVUOM040E	40	32	10	190	111	100	18	244	625
RVUOM050E	50	40	10	210	120	110	18	277	825
RVUOM063E	63	50	10	240	139	125	18	331	1250

FKM

Reference	d	DN	PN	A max	B	F	f	H	g
RVUOM020F	20	15	10	125	72	65	14	163	248
RVUOM025F	25	20	10	145	84	75	14	193	295
RVUOM032F	32	25	10	165	95	85	14	211	397
RVUOM040F	40	32	10	190	111	100	18	244	625
RVUOM050F	50	40	10	210	120	110	18	277	825
RVUOM063F	63	50	10	240	139	125	18	331	1250



RVUOM – Sediment strainer DN 15:100

- Connection system for weld, threaded and flanged joints
- **Strainer** assembled on an **easily removed support** that facilitates cleaning or replacement
- **Valve material compatibility** (PP-H) with water conveyance, drinking water and other food substances according to **current regulations**
- Can be maintained with the valve body installed