

RVUFM – Sediment strainer DN 15:100

Sediment strainer with BSP threaded female union ends.

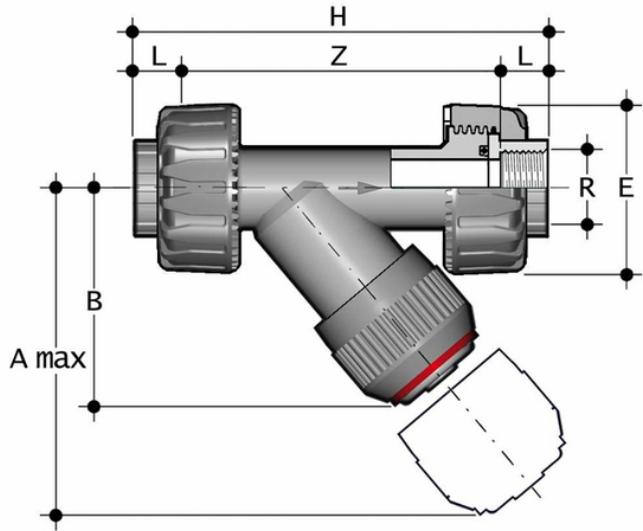

EPDM

| Reference | R | DN | PN | A max | B | E | H | Z | Fig. | g |
|-----------|--------|----|----|-------|-----|-----|-----|-----|------|------|
| RVUFM012E | 1/2" | 15 | 10 | 125 | 71 | 55 | 142 | 112 | A | 148 |
| RVUFM034E | 3/4" | 20 | 10 | 145 | 83 | 66 | 159 | 126 | A | 195 |
| RVUFM100E | 1" | 25 | 10 | 165 | 94 | 74 | 183 | 145 | A | 297 |
| RVUFM114E | 1" 1/4 | 32 | 10 | 190 | 109 | 86 | 214 | 171 | A | 475 |
| RVUFM112E | 1" 1/2 | 40 | 10 | 210 | 119 | 99 | 235 | 192 | A | 675 |
| RVUFM200E | 2" | 50 | 10 | 240 | 143 | 120 | 285 | 234 | A | 1100 |

FKM

| Reference | R | DN | PN | A max | B | E | H | Z | Fig. | g |
|-----------|--------|----|----|-------|-----|-----|-----|-----|------|------|
| RVUFM012F | 1/2" | 15 | 10 | 125 | 71 | 55 | 142 | 112 | A | 148 |
| RVUFM034F | 3/4" | 20 | 10 | 145 | 83 | 66 | 159 | 126 | A | 195 |
| RVUFM100F | 1" | 25 | 10 | 165 | 94 | 74 | 183 | 145 | A | 297 |
| RVUFM114F | 1" 1/4 | 32 | 10 | 190 | 109 | 86 | 214 | 171 | A | 475 |
| RVUFM112F | 1" 1/2 | 40 | 10 | 210 | 119 | 99 | 235 | 192 | A | 675 |
| RVUFM200F | 2" | 50 | 10 | 240 | 143 | 120 | 285 | 234 | A | 1100 |



RVUFM – Sediment strainer DN 15:100

- Connection system for weld, threaded and flanged joints
- **Strainer** assembled on an **easily removed support** that facilitates cleaning or replacement
- **Valve material compatibility** (PP-H) with water conveyance, drinking water and other food substances according to **current regulations**
- Can be maintained with the valve body installed