

RVUIM - Sediment strainer DN 15:100

Sediment strainer with female union ends for socket welding, metric series.

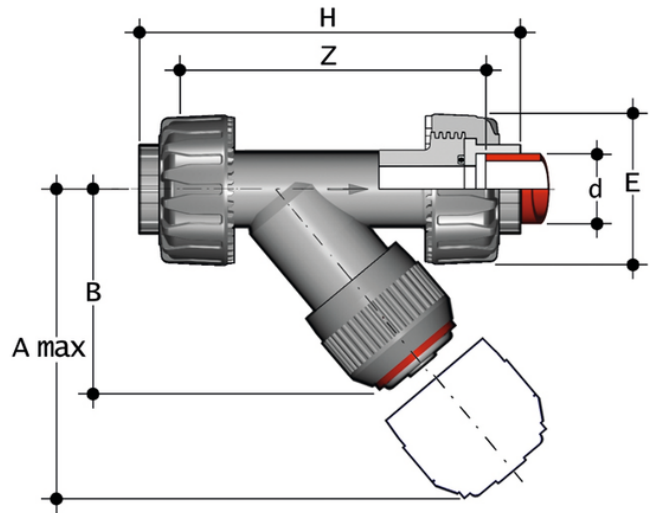

EPDM

Reference	d	DN	PN	A max	B	E	H	Z	Fig.	g
RVUIM020E	20	15	10	125	71	55	138	109	A	148
RVUIM025E	25	20	10	145	83	66	157	125	A	195
RVUIM032E	32	25	10	165	94	74	179	143	A	297
RVUIM040E	40	32	10	190	109	86	205	164	A	475
RVUIM050E	50	40	10	210	119	99	244	197	A	675
RVUIM063E	63	50	10	240	142,5	120	294	239	A	1100

FKM

Reference	d	DN	PN	A max	B	E	H	Z	Fig.	g
RVUIM020F	20	15	10	125	71	55	138	109	A	148
RVUIM025F	25	20	10	145	83	66	157	125	A	195
RVUIM032F	32	25	10	165	94	74	179	143	A	297
RVUIM040F	40	32	10	190	109	86	205	164	A	475
RVUIM050F	50	40	10	210	119	99	244	197	A	675
RVUIM063F	63	50	10	240	142,5	120	294	239	A	1100



RVUIM - Sediment strainer DN 15:100

- Connection system for weld, threaded and flanged joints
- **Strainer** assembled on an **easily removed support** that facilitates cleaning or replacement
- **Valve material compatibility** (PP-H) with water conveyance, drinking water and other food substances according to **current regulations**
- Can be maintained with the valve body installed