

# FKOF/RM LUG ISO-DIN - Butterfly valve DN 40:400

Gearbox operated butterfly valve, version Lug ISO-DIN.

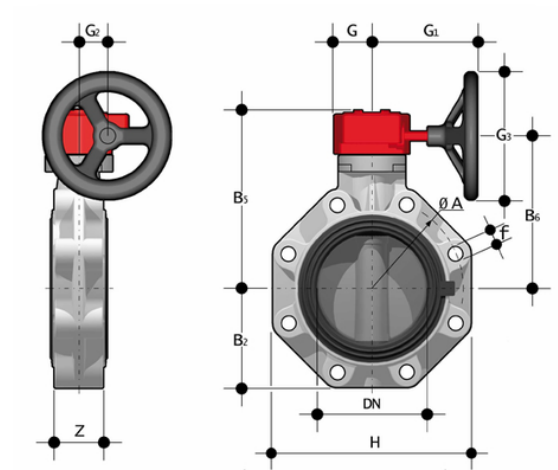

Reference	d	DN	PN	øA	B[5:2]	B[5:5]	B[5:6]	f	G	G[5:1]	G[5:2]	G[5:3]	H	U	Z	g
FKOLFRM075F	75	65	10	145	80	174	146	M16	48	135	39	125	165	4	46	2900
FKOLFRM090F	90	80	10	160	93	188	160	M16	48	135	39	125	185	12	49	3750
FKOLFRM110F	110	100	10	180	107	202	174	M16	48	135	39	125	211	8	56	4100
FKOLFRM140F	140	125	10	210	120	222	194	M16	48	144	39	200	240	8	64	6250
FKOLFRM160F	160	150	10	240	134	235	207	M20	48	144	39	200	268	8	70	7050
FKOLFRM225F	225	200	10	295	161	256	256	M20	65	204	60	200	323	8	71	11200

# FKOF/RM LUG ISO-DIN - Butterfly valve DN 40:400

- **Ergonomic handle** in HIPVC equipped with **locking and unlocking device, release, quick operation and graduated adjustment** in 10 intermediate positions (DN 40÷200). The operating range, starting from the first few degrees of valve opening, also guarantees extremely low pressure drops
- **Customisable Labelling System:** integrated module in the handle, made of a transparent protection plug and a customisable tag holder using the LSE set (available as an accessory). The **customisation** lets you **identify the valve on the system** according to specific needs
- **STAINLESS steel square section stem** completely isolated from the fluid complying with standard ISO 5211:
  - DN 40÷65: 11 mm
  - DN 80÷100: 14 mm
  - DN 125÷150: 17 mm
  - DN 200: 22 mm
  - DN 250÷400: 27 mm
- **Body** in polypropylene based **compound reinforced with fibreglass (PP-GR)** **resistant to UV rays** and characterised by **high mechanical strength**
- **Drilling pattern using oval slots** that allow coupling to flanges according to numerous international standards. The special **self-centring inserts in ABS** supplied for DN 40÷200 guarantee the **correct axial alignment** of the valve during installation. For DN 250÷400 valves, the drilling pattern for the selfcentring system is of the traditional type according to DIN and ANSI standards
- **Interchangeable liner** with the dual function of forming a hydraulic seal and isolating the body from the fluid
- Interchangeable Disk in PVDF with through shaft, available in different thermoplastic materials: PVC-U, PP-H, PVC-C, ABS
- Overall dimensions of the valve in accordance with standard ISO 5752 (DN 40÷200 Medium Series 25, DN 250÷300 Long Series 16) and DIN 3202 K2 and ISO 5752 (DN 65÷200 K2, DN 250÷300 K3)
- Can also be installed as an end line valve, bottom discharge valve or tank dump valve
- **Special Lug version** PN 10 fully drilled according to DIN 2501 or ANSI B16.5 cl.150 **with molded-in AISI 316 stainless steel threaded inserts**
- Possibility of installing a manual reducer or pneumatic and/or electric actuators by applying an ISO standard drilling PP-GR flanges. DN 40 ÷ 200 valve equipped with plate with rack in PP-GR. For actuated versions with flange drilled according to ISO 5211 F05, F07, F10. DN 250÷300 valve, fitted with one-piece top flange in high mechanical strength PP-GR with mounting flange for internal components drilled according to standard ISO 5211 F10 (excluding DN 350÷400), F12, F14
- Possibility to have handle with integrated LSQT limit micro switch, even as a retrofit in existing installations