

VVOV - Angle seat valve DN 10:50

Angle seat valve with fixed flanges, drilled PN10/16.

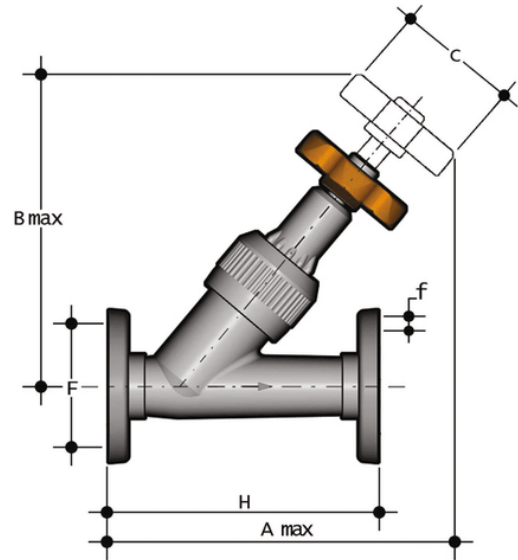

Reference	d	DN	PN	A max	B max	C	F	f	H	g
VVOV020E	20	15	16	146	124	60	65	14	130	300
VVOV025E	25	20	16	166	146	60	75	14	150	455
VVOV032E	32	25	16	191	173	70	85	14	160	655
VVOV040E	40	32	10	219	195	85	100	18	180	1025
VVOV050E	50	40	10	249	222	105	110	18	200	1390
VVOV063E	63	50	10	302	269	130	125	18	230	2155



VVOV – Angle seat valve DN 10:50

- Connection system for solvent weld, threaded and flanged joints
- Can be installed in any position
- **No metal parts in contact with the fluid**
- **Valve material compatibility** (PVC-U) with water, drinking water and other food substance conveyance according to **current regulations**
- Can be maintained with the valve body installed