

DKUFC - DIALOCK® 2-way diaphragm valve DN 15:65

DIALOCK® diaphragm valve with BSP threaded female union ends.

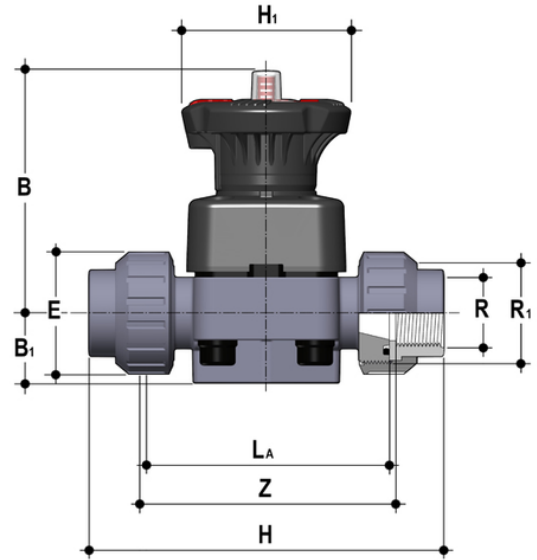

EPDM

Reference	R	DN	PN	B	B ₁	E	H	H ₁	La	R ₁	Z	g
DKUFC012E	1/2"	15	10	102	25	41	131	80	90	1"	97	509
DKUFC034E	3/4"	20	10	105	30	50	151	80	108	1 1/4"	118	576
DKUFC100E	1"	25	10	114	33	58	165	80	116	1 1/2"	127	812
DKUFC114E	1 1/4"	32	10	119	30	72	188	80	134	2"	145	945
DKUFC112E	1 1/2"	40	10	149	35	79	208	120	154	2 1/2"	165	1814
DKUFC200E	2"	50	10	172	46	98	246	120	184	2 3/4"	195	2752

FKM

Reference	R	DN	PN	B	B ₁	E	H	H ₁	La	R ₁	Z	g
DKUFC012F	1/2"	15	10	102	25	41	131	80	90	1"	97	509
DKUFC034F	3/4"	20	10	105	30	50	151	80	108	1 1/4"	118	576
DKUFC100F	1"	25	10	114	33	58	165	80	116	1 1/2"	127	812
DKUFC114F	1 1/4"	32	10	119	30	72	188	80	134	2"	145	945
DKUFC112F	1 1/2"	40	10	149	35	79	208	120	154	2 1/2"	165	1814
DKUFC200F	2"	50	10	172	46	98	246	120	184	2 3/4"	195	2752

PTFE



DKUFC - DIALOCK® 2-way diaphragm valve DN 15:65

Reference	R	DN	PN	B	B ₁	E	H	H ₁	La	R ₁	Z	g
DKUFC012P	1/2"	15	10	102	25	41	131	80	90	1"	97	509
DKUFC034P	3/4"	20	10	105	30	50	151	80	108	1"1/4	118	576
DKUFC100P	1"	25	10	114	33	58	165	80	116	1"1/2	127	812
DKUFC114P	1"1/4	32	10	119	30	72	188	80	134	2"	145	945
DKUFC112P	1"1/2	40	10	149	35	79	208	120	154	2"1/2	165	1814
DKUFC200P	2"	50	10	172	46	98	246	120	184	2"3/4	195	2752

DKUFC – DIALOCK® 2-way diaphragm valve DN 15:65

- **High visibility graduated optical position indicator** protected by a transparent cap with seal O-Ring
- **Customisation plate:** the customisation lets you identify the valve on the system according to specific needs
- **DIALOCK® SYSTEM:** innovative handwheel with a patented immediate and ergonomic operating locking device that allows it **to be adjusted and locked in over 300 positions**
- **Handwheel and bonnet in** high mechanical strength and chemically resistant **PP-GR**, providing full protection by isolating all internal metal parts from contact with external agents
- **Floating pin connection** between the control screw and diaphragm to prevent concentrated loads, improve the seal and extend its lifetime
- **New design of valve body interior: substantially increased flow coefficient** and reduced pressure drop. The degree of efficiency reached has also **enabled the size and weight of the valve to be reduced**
- **Adjustment linearity:** the internal profiles of the valve also greatly improve its characteristic curve, resulting in **extremely sensitive and precise adjustment** along the entire stroke of the shutter
- **Valve anchoring** bracket **integrated in the body**, with threaded metal inserts allowing **simple panel or wall mounting** using the PMDK mounting plate (supplied as an accessory)

- Connection system for solvent weld, threaded and flanged joints
- **Optimised fluid dynamic design:** maximum output flow rate thanks to the optimised efficiency of the fluid dynamics that characterise the new internal geometry of the body
- **Internal components in metal, totally isolated from the fluid** and external environment
- **Modularity of the range:** only 2 handwheel and 4 diaphragm and bonnet sizes for 7 different valve sizes
- Non-rising handwheel that stays at the same height during rotation, equipped with a graduated optical indicator protected by a transparent PVC cap with seal O-Ring
- Bonnet fastening screws in stainless steel protected against the external environment by PE plugs. Absence of metal parts exposed to the external environment to prevent any risk of corrosion.
- **CDSA** (Circular Diaphragm Sealing Angle) system that, thanks to the uniform distribution of shutter pressure on the diaphragm seal, offers the following advantages:
 - reduction in the tightening torque of the screws fixing the actuator to the valve body
 - reduced mechanical stress on all valve components (actuator, body and diaphragm)
 - easy to clean valve interior
 - low risk of the accumulation of deposits, contamination or damage to the diaphragm due to crystallisation
 - operating torque reduction