

DKOM – DIALOCK® 2-way diaphragm valve DN 15:65

DIALOCK® diaphragm valve with flanged monolithic body, drilled PN10/16. Face to face according to EN 558-1.

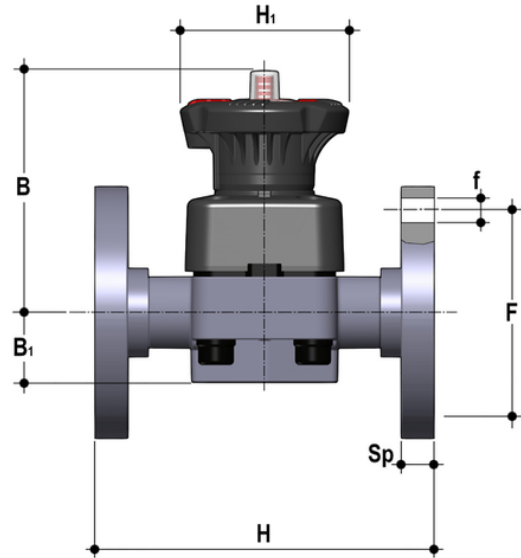

EPDM

Reference	d	DN	PN	B	B ₁	F	f	H	H ₁	Sp	U	g
DKOM020E	20	15	10	102	25	65	14	130	80	13,5	4	817
DKOM025E	25	20	10	105	30	75	14	150	80	13,5	4	850
DKOM032E	32	25	10	114	33	85	14	160	80	13,5	4	892
DKOM040E	40	32	10	119	30	100	18	180	80	14	4	1005
DKOM050E	50	40	10	149	35	110	18	200	120	16	4	1771
DKOM063E	63	50	10	172	46	125	18	230	120	16	4	2453
DKOM075E	75	65	10	172	46	145	18	290	120	21	4	2997

FKM

Reference	d	DN	PN	B	B ₁	F	f	H	H ₁	Sp	U	g
DKOM020F	20	15	10	102	25	65	14	130	80	13,5	4	817
DKOM025F	25	20	10	105	30	75	14	150	80	13,5	4	850
DKOM032F	32	25	10	114	33	85	14	160	80	13,5	4	892
DKOM040F	40	32	10	119	30	100	18	180	80	14	4	1005
DKOM050F	50	40	10	149	35	110	18	200	120	16	4	1771
DKOM063F	63	50	10	172	46	125	18	230	120	16	4	2453
DKOM075F	75	65	10	172	46	145	18	290	120	21	4	2997

DKOM - DIALOCK® 2-way diaphragm valve DN 15:65

PTFE

Reference	d	DN	PN	B	B ₁	F	f	H	H ₁	Sp	U	g
DKOM063P	63	50	10	172	46	125	18	230	120	16	4	2453
DKOM075P	75	65	10	172	46	145	18	290	120	21	4	2997
DKOM020P	20	15	10	102	25	65	14	130	80	13,5	4	817
DKOM025P	25	20	10	105	30	75	14	150	80	13,5	4	850
DKOM032P	32	25	10	114	33	85	14	160	80	13,5	4	892
DKOM040P	40	32	10	119	30	100	18	180	80	14	4	1005
DKOM050P	50	40	10	149	35	110	18	200	120	16	4	1771

DKOM – DIALOCK® 2-way diaphragm valve DN 15:65

- **High visibility graduated optical position indicator** protected by a transparent cap with seal O-Ring
- **Customisation plate:** the customisation lets you identify the valve on the system according to specific needs
- **DIALOCK® SYSTEM:** innovative handwheel with a patented immediate and ergonomic operating locking device that allows it **to be adjusted and locked in over 300 positions**
- **Handwheel and bonnet in** high mechanical strength and chemically resistant **PP-GR**, providing full protection by isolating all internal metal parts from contact with external agents
- **Floating pin connection** between the control screw and diaphragm to prevent concentrated loads, improve the seal and extend its lifetime
- **New design of valve body interior: substantially increased flow coefficient** and reduced pressure drop. The degree of efficiency reached has also **enabled the size and weight of the valve to be reduced**
- **Adjustment linearity:** the internal profiles of the valve also greatly improve its characteristic curve, resulting in **extremely sensitive and precise adjustment** along the entire stroke of the shutter
- **Valve anchoring** bracket **integrated in the body**, with threaded metal inserts allowing **simple panel or wall mounting** using the PMDK mounting plate (supplied as an accessory)

- Connection system for solvent weld, threaded and flanged joints
- **Optimised fluid dynamic design:** maximum output flow rate thanks to the optimised efficiency of the fluid dynamics that characterise the new internal geometry of the body
- **Internal components in metal, totally isolated from the fluid** and external environment
- **Modularity of the range:** only 2 handwheel and 4 diaphragm and bonnet sizes for 7 different valve sizes
- Non-rising handwheel that stays at the same height during rotation, equipped with a graduated optical indicator protected by a transparent PVC cap with seal O-Ring
- Bonnet fastening screws in stainless steel protected against the external environment by PE plugs. Absence of metal parts exposed to the external environment to prevent any risk of corrosion
- **CDSA** (Circular Diaphragm Sealing Angle) system that, thanks to the uniform distribution of shutter pressure on the diaphragm seal, offers the following advantages:
 - reduction in the tightening torque of the screws fixing the actuator to the valve body
 - reduced mechanical stress on all valve components (actuator, body and diaphragm)
 - easy to clean valve interior
 - low risk of the accumulation of deposits, contamination or damage to the diaphragm due to crystallisation
 - operating torque reduction