

# VRUOM – Check valve DN 15:80

Check valve with union ends and fixed flanges, drilled EN/ISO/DIN PN10/16.

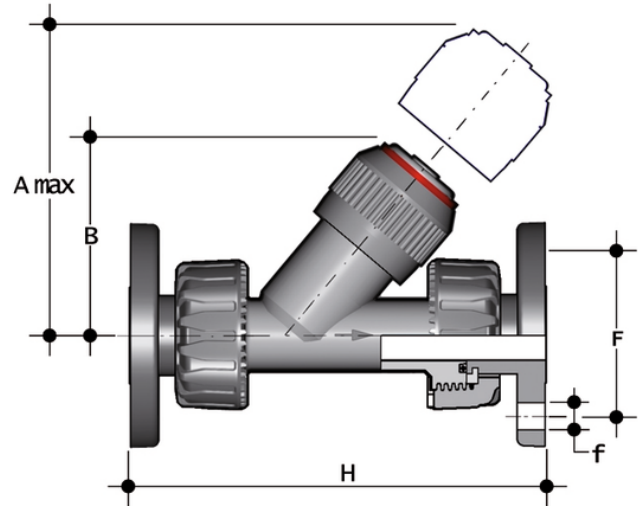

## EPDM

Reference	d	DN	PN	A max	B	F	f	H	g
VRUOM020E	20	15	10	125	72	65	14	163	265
VRUOM025E	25	20	10	145	84	75	14	193	327
VRUOM032E	32	25	10	165	95	85	14	211	480
VRUOM040E	40	32	10	190	111	100	18	244	795
VRUOM050E	50	40	10	210	120	110	18	277	1065
VRUOM063E	63	50	10	240	139	125	18	331	1705

## FKM

Reference	d	DN	PN	A max	B	F	f	H	g
VRUOM020F	20	15	10	125	72	65	14	163	265
VRUOM025F	25	20	10	145	84	75	14	193	327
VRUOM032F	32	25	10	165	95	85	14	211	480
VRUOM040F	40	32	10	190	111	100	18	244	795
VRUOM050F	50	40	10	210	120	110	18	277	1065
VRUOM063F	63	50	10	240	139	125	18	331	1705



## VRUOM – Check valve DN 15:80

- Connection system for weld, threaded and flanged joints
- **No metal parts in contact with the fluid**
- **Piston with counterweight** able to work with high intensity fluid
- Limited pressure drop. Only minimum back pressure is required for the hermetic seal
- **Valve material compatibility** (PP-H) with water conveyance, drinking water and other food substances according to **current regulations**
- Can be maintained with the valve body installed